

**TECENSTAR**

|      |  |      |                   |
|------|--|------|-------------------|
| Add: | 5/F, Building B, Xingnan Industrial Zone, Lianping Administrative District, Dalingshan Town, Dongguan, China |      |                   |
| Tel: | +86-769-8286 8210  | Fax: | +86-769 8286 8212 |

# SPECIFICATION

## COG-T350MPNO-01P

- Preliminary Specification
- Final Specification



**TECENSTAR PHOTOELECTRIC  
TECHNOLOGY CO., LTD.**

**CUSTOMER:**

**Made By:**

**Checked By:**

**Approved By:**

**Quality:**

**Date:**

**Note:**

**Approved By:**

**Date:**

**Note:**

## Records of Revision

| DATE       | REF.PAGE<br>PARAGRAPH<br>DRAWING No. | REVISED<br>No. | SUMMARY     | REMARK |
|------------|--------------------------------------|----------------|-------------|--------|
| 2015-11-21 |                                      | V01            | First Issue |        |
|            |                                      |                |             |        |
|            |                                      |                |             |        |
|            |                                      |                |             |        |
|            |                                      |                |             |        |
|            |                                      |                |             |        |
|            |                                      |                |             |        |
|            |                                      |                |             |        |
|            |                                      |                |             |        |
|            |                                      |                |             |        |
|            |                                      |                |             |        |
|            |                                      |                |             |        |
|            |                                      |                |             |        |
|            |                                      |                |             |        |
|            |                                      |                |             |        |
|            |                                      |                |             |        |
|            |                                      |                |             |        |
|            |                                      |                |             |        |
|            |                                      |                |             |        |
|            |                                      |                |             |        |
|            |                                      |                |             |        |
|            |                                      |                |             |        |
|            |                                      |                |             |        |
|            |                                      |                |             |        |
|            |                                      |                |             |        |

## Contents

|  |    |
|--|----|
| 1. General Specification.....                  | 4  |
| 2. Mechanical Drawing.....                     | 5  |
| 3. Block Diagram.....                          | 6  |
| 4. Interface Pin Function.....                 | 7  |
| 5. Absolute Maximum Ratings.....               | 8  |
| 6. Electrical Characteristics.....             | 9  |
| 7. Optical Characteristics.....                | 10 |
| 8. Timing Characteristics.....                 | 14 |
| 9. Standard Specification for Reliability..... | 16 |
| 10. Specification of Quality Assurance.....    | 18 |
| 11. Handling Precaution.....                   | 27 |
| 12. Packing Method.....                        | 27 |

# 1. General Specification

| <b>Item</b>                    | <b>Contents</b>  | <b>Unit</b> |
|--------------------------------|------------------|-------------|
| LCD TYPE                       | TFT/TRANSMISSIVE |             |
| MODULE SIZE (W*H*T)            | 86.80*56.50*3.90 | MM          |
| ACTIVE SIZE (W*H)              | 77.76*43.52      | MM          |
| PIXEL PITCH (W*H)              | 0.162*0.16       | MM          |
| NUMBER OF DOTS                 | 480*272          |             |
| DIVER IC                       | OTA5180A         |             |
| INTERFACE TYPE                 | 24 BITS RGB      |             |
| TOP POLARIZER TYPE             | ANTI-GLARE       |             |
| RECOMMEND VIEWING DIRECTION    | 6                | O'CLOCK     |
| GRAY SCALE INVERSION DIRECTION | 12               | O'CLOCK     |
| COLORS                         | 16.7M            |             |
| BACKLIGHT TYPE                 | 6-DIES WHITE LED |             |
| TOUCH PANEL TYPE               | RESISTIVE TP     |             |

## 2. Mechanical Drawing

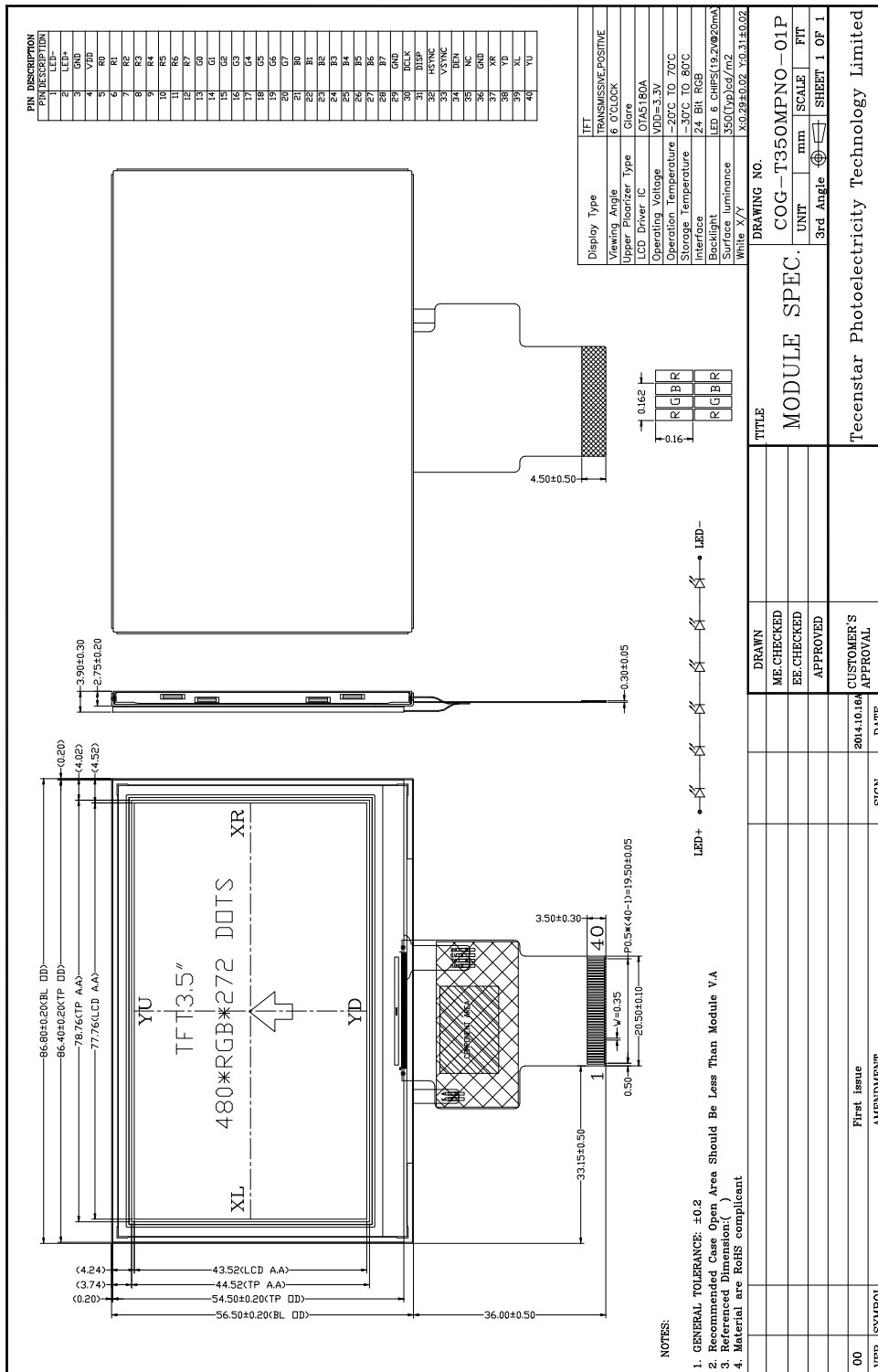

### 3. Block Diagram

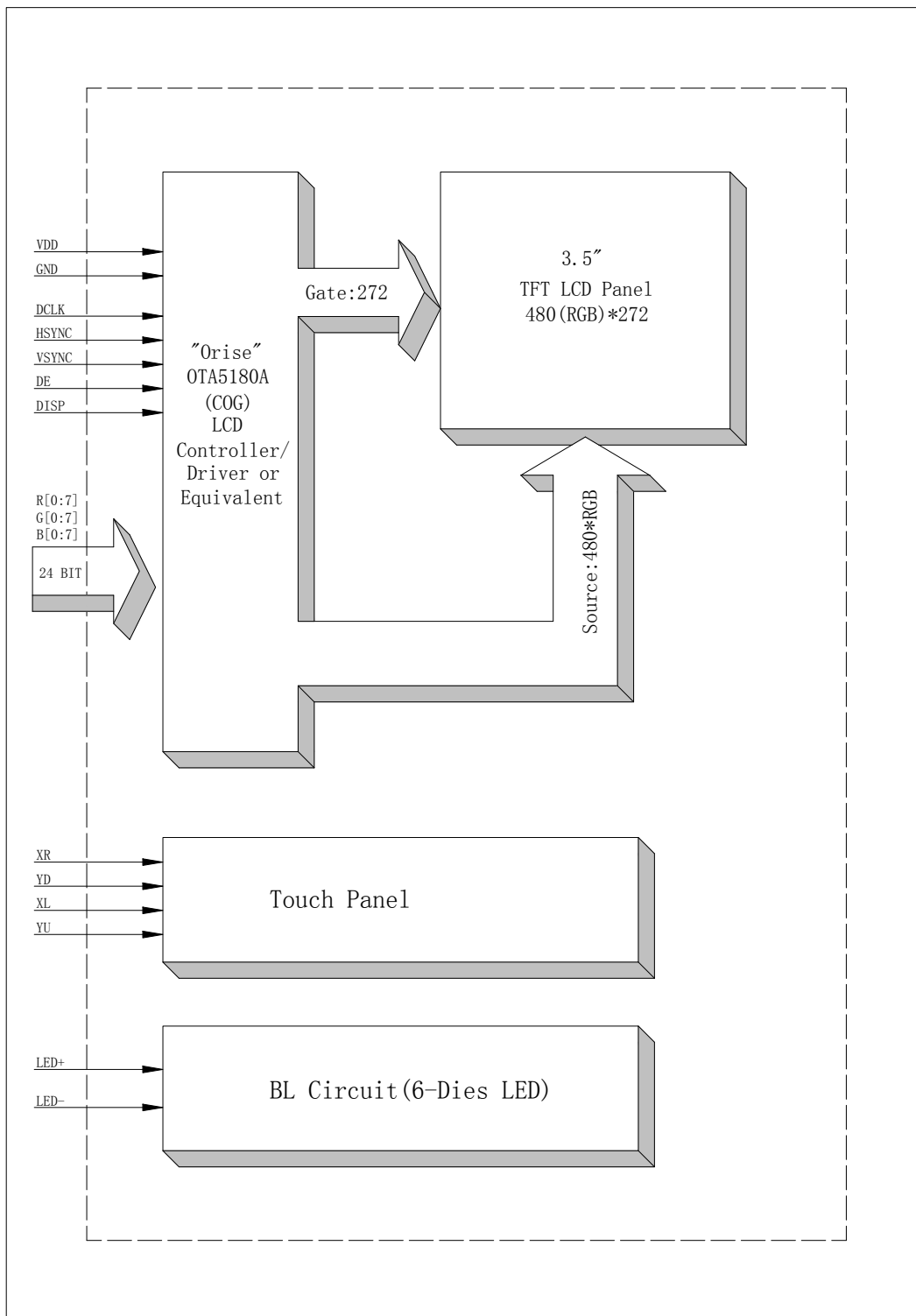

## 4. Interface Pin Function

| Pin No. | Symbol | Description               |
|---------|--------|---------------------------|
| 1       | LED-   | Cathode of LED back light |
| 2       | LED+   | Anode of LED back light   |
| 3       | GND    | Power ground              |
| 4       | VDD    | Power voltage             |
| 5       | R0     | Red data bus              |
| 6       | R1     | Red data bus              |
| 7       | R2     | Red data bus              |
| 8       | R3     | Red data bus              |
| 9       | R4     | Red data bus              |
| 10      | R5     | Red data bus              |
| 11      | R6     | Red data bus              |
| 12      | R7     | Red data bus              |
| 13      | G0     | Green data bus            |
| 14      | G1     | Green data bus            |
| 15      | G2     | Green data bus            |
| 16      | G3     | Green data bus            |
| 17      | G4     | Green data bus            |
| 18      | G5     | Green data bus            |
| 19      | G6     | Green data bus            |
| 20      | G7     | Green data bus            |
| 21      | B0     | Blue data bus             |
| 22      | B1     | Blue data bus             |
| 23      | B2     | Blue data bus             |
| 24      | B3     | Blue data bus             |
| 25      | B4     | Blue data bus             |
| 26      | B5     | Blue data bus             |
| 27      | B6     | Blue data bus             |
| 28      | B7     | Blue data bus             |
| 29      | GND    | Power ground              |
| 30      | DCLK   | Dot clock signal          |
| 31      | DISP   | Display control pin       |
| 32      | HSYNC  | Horizon signal YNC        |
| 33      | VSYNC  | Vertical signal YNC       |
| 34      | DEN    | Data enable signal        |
| 35      | NC     | No connect                |
| 36      | GND    | Power ground              |
| 37      | XR     | TP pin                    |
| 38      | YD     | TP pin                    |
| 39      | XL     | TP pin                    |
| 40      | YU     | TP pin                    |

## 5. Absolute Maximum Ratings

| Parameter                 | Symbol           | Min  | Max | Unit |
|---------------------------|------------------|------|-----|------|
| Supply voltage for analog | VDD              | -0.3 | 4.5 | V    |
| Supply voltage for logic  | VDD              | -0.3 | 4.5 | V    |
| Supply current (One LED)  | I <sub>LED</sub> |      | 30  | mA   |
| Operating temperature     | T <sub>OP</sub>  | -20  | +70 | °C   |
| Storage temperature       | T <sub>ST</sub>  | -30  | +80 | °C   |

Note: The absolute maximum rating values of this product are not allowed to be exceeded at any times. Should a module be used with any of the absolute maximum ratings exceeded, the characteristics of the module may not be recovered, or in an extreme case, the module may be permanently destroyed.



## 6. Electrical Characteristics

### 6.1 Input Power

| Item                      | Symbol           | Min     | Typ. | Max    | Unit | Applicable terminal |
|---------------------------|------------------|---------|------|--------|------|---------------------|
| Supply Voltage for Analog | VDD              | 3.0     | 3.3  | 3.6    | V    |                     |
| Supply Voltage for Logic  | VDD              | 3.0     | 3.3  | 3.6    | V    |                     |
| Input Voltage             | V <sub>IL</sub>  | GND     | -    | 0.3VDD | V    |                     |
|                           | V <sub>IH</sub>  | 0.7 VDD | -    | VDD    |      |                     |
| Input leakage Current     | I <sub>LKG</sub> | -1      |      | 1      | μA   |                     |

### 6.2 Backlight Driving Conditions

| Item                      | Symbol         | Value  |        |      | Unit | Remark               |
|---------------------------|----------------|--------|--------|------|------|----------------------|
|                           |                | Min.   | Typ.   | Max. |      |                      |
| Voltage for LED Backlight | V <sub>F</sub> | -      | 19.2   | -    | V    | I <sub>L</sub> =20mA |
| Current for LED Backlight | I <sub>L</sub> |        | 20     | 30   | mA   |                      |
| Power Consumption         | P              |        | 0.384  |      | W    |                      |
| LED Life Time             |                | 30,000 | 50,000 |      | Hr   | Note                 |

**Note:** Brightness to be decreased to 50% of the initial value at ambient temperature TA=25°C

## 7. Optical Characteristics

| ITEM                 | SYMBOL           | CONDITIONS          | SPECIFICATIONS       |      |       | UNIT            | NOTE |
|----------------------|------------------|---------------------|----------------------|------|-------|-----------------|------|
|                      |                  |                     | MIN                  | TYP. | MAX   |                 |      |
| Luminance            | L                | $I_L = 20\text{mA}$ |                      | 350  |       | $\text{Cd/m}^2$ |      |
| Contrast Ratio       | CR               | $\theta = 0^\circ$  |                      |      |       |                 |      |
| Response Time        | $T_{\text{ON}}$  | $25^\circ\text{C}$  |                      | 35   | 50    | ms              |      |
|                      | $T_{\text{OFF}}$ |                     |                      |      |       |                 |      |
| CIE Color Coordinate | Red              | $X_R$               | Viewing normal angle |      |       |                 |      |
|                      |                  | $Y_R$               |                      |      |       |                 |      |
|                      | Green            | $X_G$               |                      |      |       |                 |      |
|                      |                  | $Y_G$               |                      |      |       |                 |      |
|                      | Blue             | $X_B$               |                      |      |       |                 |      |
|                      |                  | $Y_B$               |                      |      |       |                 |      |
|                      | White            | $X_W$               |                      |      | 0.290 |                 |      |
|                      |                  | $Y_W$               |                      |      | 0.310 |                 |      |
| Viewing Angle        | Hor.             | $\theta_{X+}$       | $CR \geq 10$         |      | 60    | Degree          |      |
|                      |                  | $\theta_{X-}$       |                      |      | 60    |                 |      |
|                      | Ver.             | $\theta_{Y+}$       |                      |      | 60    |                 |      |
|                      |                  | $\theta_{Y-}$       |                      |      | 50    |                 |      |
| Uniformity           | Un               |                     |                      | 80   |       | %               |      |

**Note 1: Definition of Viewing Angle  $\theta_x$  and  $\theta_y$ :**

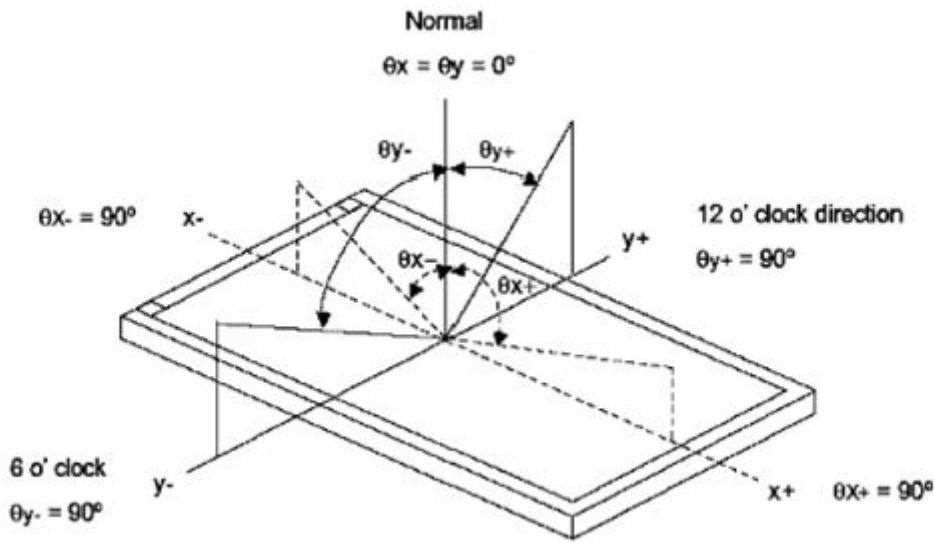

**Note 2: Definition of contrast ratio CR:**

$$CR = \frac{\text{Luminance of white state}}{\text{Luminance of black state}}$$

**Note 3: Definition of Response Time ( $T_r, T_f$ )**

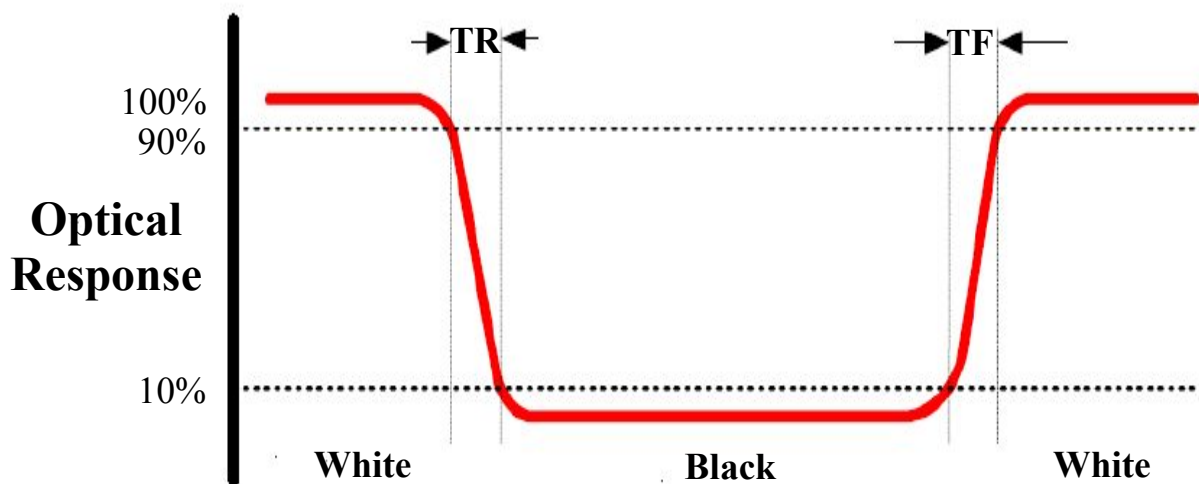

## Note 4: Definition of Luminance

### ①The Brightness Test Equipment Setup

Field=2° (As measuring “black” image, field=2° is the best testing condition)

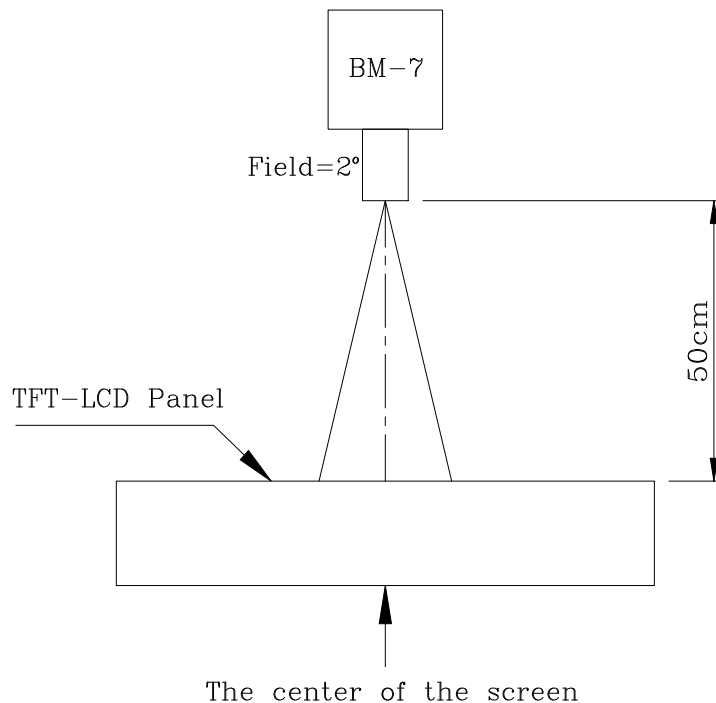

### ②The Brightness Test Point Setup

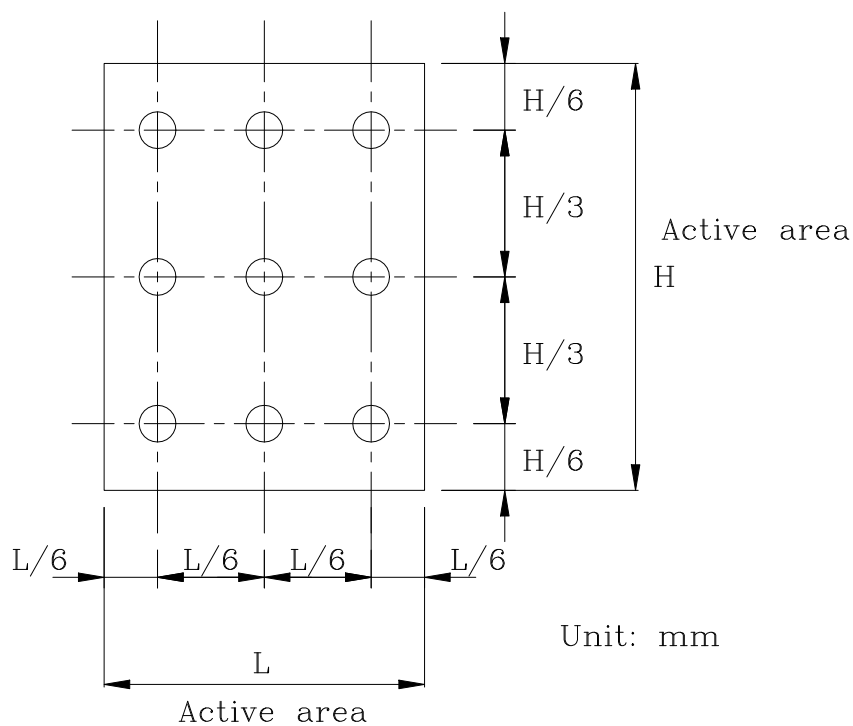

## 8. Timing Characteristics

### 8.1 SYNC-DE Mode Timing Diagram

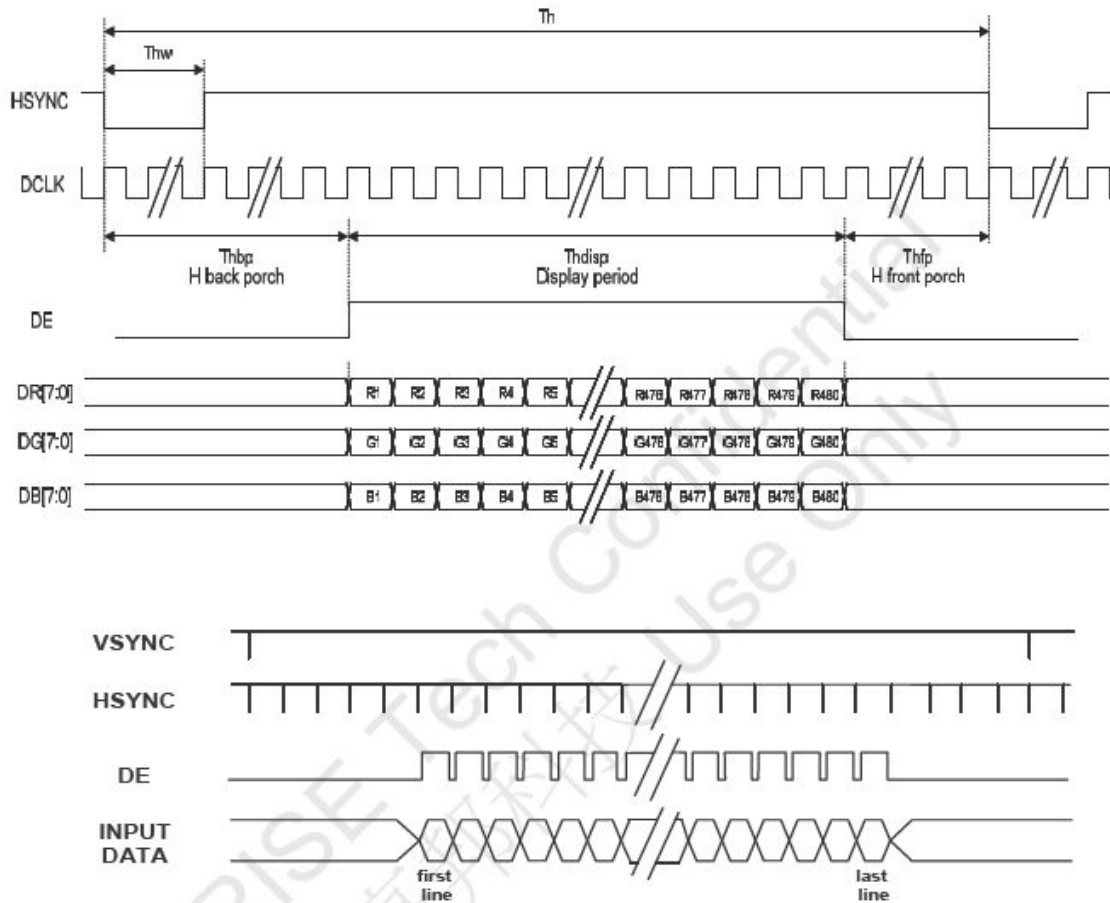

## 8.2 SYNC Timing Diagram

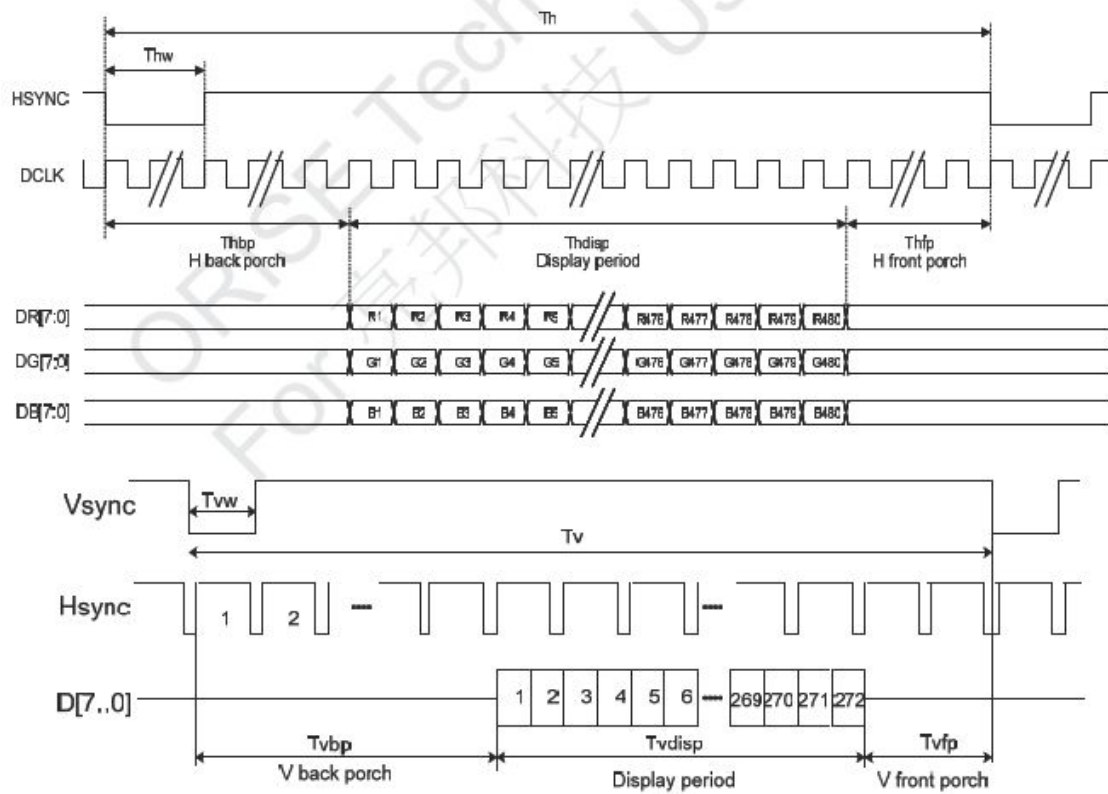

## 8.3 Parallel Timing table

| Item           | Symbol         | Min.   | Typ. | Max. | Unit |      |                       |
|----------------|----------------|--------|------|------|------|------|-----------------------|
| DCLK Frequency | Fclk           | 5      | 9    | 12   | MHz  |      |                       |
| DCLK Period    | Tclk           | 83     | 110  | 200  | ns   |      |                       |
| Hsync          | Period Time    | Th     | 490  | 531  | 605  | DCLK |                       |
|                | Display Period | Thdisp |      | 480  |      | DCLK |                       |
|                | Back Porch     | Thbp   | 8    | 43   |      | DCLK | By H_BLANKING setting |
|                | Front Porch    | Thfp   | 2    | 8    |      | DCLK |                       |
|                | Pulse Width    | Thw    | 1    |      |      | DCLK |                       |
| Vsync          | Period Time    | Tv     | 275  | 288  | 335  | H    |                       |
|                | Display Period | Tvdisp |      | 272  |      | H    |                       |
|                | Back Porch     | Tvbp   | 2    | 12   |      | H    | By V_BLANKING setting |
|                | Front Porch    | Tvfp   | 1    | 4    |      | H    |                       |
|                | Pulse Width    | Tww    | 1    | 10   |      | H    |                       |

## 8.4 Power ON/OFF Sequence

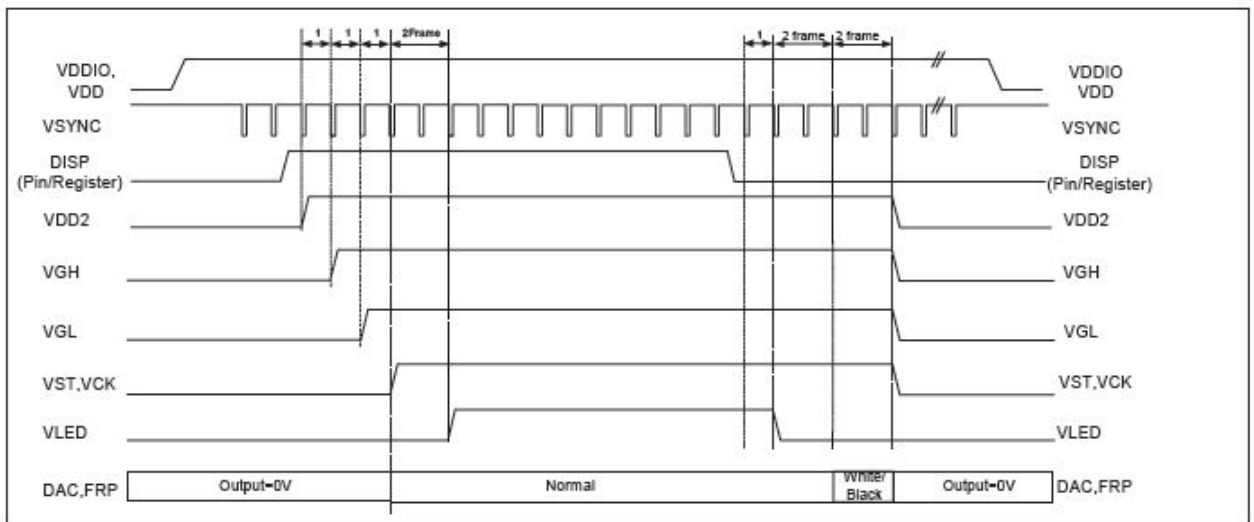

Fig. Power Sequence

**Note:**

- a. When MVA mode (Normally black LC) is applied, it needs to send **black pattern** to discharge the pixel.
- b. When TN\_MODE2 or TN\_MODE1 mode (Normally white LC) is applied, it needs to send **white pattern** to discharge the pixel.

## 9. Standard Specification for Reliability

### 9.1 Standard Specification for Reliability of LCD Module

| No. | Item                        | Description   |
|-----|-----------------------------|---|
| 01  | High temperature operation  | The sample should be allowed to stand at 70°C for 120 hours under driving condition and then returning it to normal temperature condition, and allowing it stand for 2 hours.                       |
| 02  | Low temperature operation   | The sample should be allowed to stand at -20°C for 120 hours under driving condition and then returning it to normal temperature condition, and allowing it stand for 2 hours.                      |
| 03  | High temperature storage    | The sample should be allowed to stand at 80°C for 240 hours under no-load condition, and then returning it to normal temperature condition and allowing it stand for 2 hours.                       |
| 04  | Low temperature storage     | The sample should be allowed to stand at -30°C for 240 hours under no-load condition, then returning it to normal temperature condition, and allowing it stand for 2 hours.                         |
| 05  | Moisture storage            | The sample should be allowed to stand at 60°C, 90%RH MAX for 240 hours under no-load condition, then taking it out and drying it at normal temperature for 2 hours.                                 |
| 06  | Thermal shock storage       | The sample should be allowed to stand the following 10 cycles :<br>-30°C for 30 minutes → normal temperature for 5 minutes → +80°C for 30 minutes → normal temperature for 5 minutes, as one cycle. |
| 07  | Packing vibration           | Frequency range : 10Hz ~ 55Hz<br>Amplitude of vibration : 1.5mm Sweep time: 12 min<br>X, Y, Z 2 hours for each direction.   |
| 08  | Packing drop test           | According to ASTM-D-5327.   |
| 09  | Electrical Static Discharge | Air: ±4KV 150pF/330Ω 5 times  |
|     |                             | Contact: ±2KV 150pF/330Ω 5 time   |

\*Sample size for each test item is 3~5pcs



## 9.2 Testing Conditions and Inspection Criteria

For the final test, the testing sample must be stored at room temperature for 24 hours. After the tests listed in Table 9.2, standard specifications for reliability will be executed in order to ensure stability.

| No. | Item                | Test Model             | In section Criteria  |
|-----|---------------------|------------------------|--|
| 01  | Current Consumption | Refer To Specification | The current consumption should conform to the product specification.   |
| 02  | Contrast            | Refer To Specification | After the tests have been executed, the contrast must be larger than half of its initial value prior to the tests. |
| 03  | Appearance          | Visual inspection      | Defect free.   |

## 9.3 MTBF

|      |   |
|------|---|
| MTBF | Functions, performance, appearance, etc. shall be free from remarkable deterioration within 50,000 hours under ordinary operating and storage conditions room temperature ( $25\pm 5^{\circ}\text{C}$ ), normal humidity ( $50\pm 10\%$ RH), and in area not exposed to direct sun light. |
|------|---|

## 10. Specification of Quality Assurance

This standard of Quality Assurance confirms to the quality of LCD module products supplied by Tecenstar.

### 10.1 Quality Test

Before delivering, the supplier should conduct the following tests to confirm the quality of products.

- Electrical-Optical Characteristics: According to the individual specification to test the product.
- Appearance Characteristics: According to the individual specification to test the product.
- Reliability Characteristics: According to the definition of reliability on the specification for testing products.

### 10.2 Delivery Test

Before delivering, the supplier should conduct the delivery test.

- Test method: According to MIL-STD105E.General Inspection Level II take a single time.
- The defects classify of AQL as following:  
Major defect: AQL = 0.65  
Minor defect: AQL = 2.5  
Total defects: AQL = 2.5

### 10.3 Non-conforming Analysis & Deal with Manners

#### 10.3.1 Non-conforming Analysis

- Purchaser should provide the data detail of non-conforming sample and the non-conforming.
- After receiving the data detail from purchaser, the analysis of non-conforming should be finished within two weeks.
- If the analysis can't be finished on time, supplier must notice purchaser 3 days in advance.

#### 10.3.2 Disposition of non-conforming

- If any product defect be found during assembling, supplier must change the good for every defect after confirmation.
- Both supplier and customer should analyze the reason and discuss the disposition of non-conforming when the reason of nonconforming is not sure.

## 10.4 Agreement items

Both parties should negotiate together when the following problems happen.

- There is any problem of standard of quality assurance, and both sides should agree that it must be modified.
- There is any argument item which does not record in the standard of quality assurance.
- Any other special problem.

## 10.5 Standard of the Product Appearance Test

### 10.5.1 Manner of appearance test

- The test must be under 20W × 2 or 40W fluorescent light, and the distance of view must be at 30±5cm.
- When test the model of transmissive product must add the reflective plate.
- The test direction is base on around 10° of vertical line.
- Temperature: 25±5°C Humidity: 60±10%RH

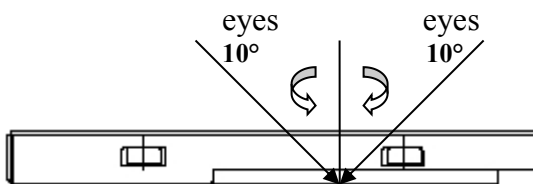

- Definition of area:

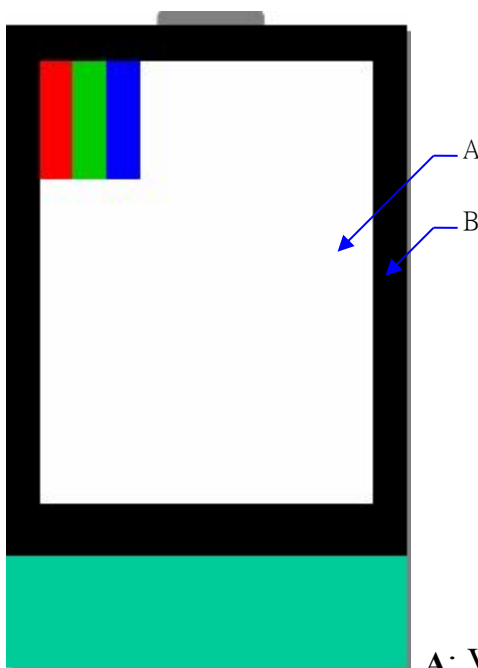

A: Viewing area B: Outside viewing area

### 10.5.2 Basic principle

- When the standard cannot be described, AQL will be applied.
- The sample of the lowest acceptable quality level must be negotiated by both supplier and customer when any dispute happened.
- New item must be added on time when it is necessary.

## 10.6 Inspection Specification

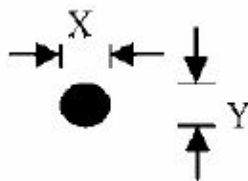
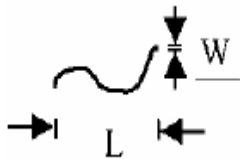
| NO.   | Item  | Criterion  | AQL             |                 |                  |                 |                         |                      |                         |              |                         |     |               |           |     |
|---|---|--|-----------------|-----------------|------------------|-----------------|-------------------------|----------------------|-------------------------|--------------|-------------------------|-----|---------------|-----------|-----|
| 01  | Electrical Testing  | 1.1 Missing vertical, horizontal segment, segment contrast defect.<br>1.2 Missing character, dot or icon.<br>1.3 Display malfunction.<br>1.4 No function or no display.<br>1.5 Current consumption exceeds product specifications.<br>1.6 LCD viewing angle defect.<br>1.7 Mixed product types.<br>1.8 Flicker   | 0.65            |                 |                  |                 |                         |                      |                         |              |                         |     |               |           |     |
| 02  | Black or White spots or Bright spots or Color spots on LCD (Display only)   | 2.1 White and black or color spots on display $\leq 0.25\text{mm}$ , no more than Five spots.<br>2.2 Densely spaced: No more than three spots within 3mm.  | 2.5             |                 |                  |                 |                         |                      |                         |              |                         |     |               |           |     |
| 03  | LCD and Touch Panel black spots, white spots, contamination (non – display) | 3.1 Round type: As following drawing<br>$\Phi = (X+Y) / 2$  <table border="1" data-bbox="821 1120 1348 1377"> <thead> <tr> <th>Size(mm)</th> <th>Acceptable Q'ty</th> </tr> </thead> <tbody> <tr> <td><math>\Phi \leq 0.10</math></td> <td>Accept no dense</td> </tr> <tr> <td><math>0.10 &lt; \Phi \leq 0.20</math></td> <td>2</td> </tr> <tr> <td><math>0.20 &lt; \Phi \leq 0.25</math></td> <td>2</td> </tr> <tr> <td><math>0.25 &lt; \Phi \leq 0.30</math></td> <td>1</td> </tr> <tr> <td><math>0.30 &lt; \Phi</math></td> <td>0</td> </tr> </tbody> </table> <p>* Densely spaced: No more than two spots within 3mm.</p> | Size(mm)        | Acceptable Q'ty | $\Phi \leq 0.10$ | Accept no dense | $0.10 < \Phi \leq 0.20$ | 2                    | $0.20 < \Phi \leq 0.25$ | 2            | $0.25 < \Phi \leq 0.30$ | 1   | $0.30 < \Phi$ | 0         | 2.5 |
|   |   | Size(mm)   | Acceptable Q'ty |                 |                  |                 |                         |                      |                         |              |                         |     |               |           |     |
| $\Phi \leq 0.10$  | Accept no dense   |  |                 |                 |                  |                 |                         |                      |                         |              |                         |     |               |           |     |
| $0.10 < \Phi \leq 0.20$   | 2   |  |                 |                 |                  |                 |                         |                      |                         |              |                         |     |               |           |     |
| $0.20 < \Phi \leq 0.25$   | 2   |  |                 |                 |                  |                 |                         |                      |                         |              |                         |     |               |           |     |
| $0.25 < \Phi \leq 0.30$   | 1   |  |                 |                 |                  |                 |                         |                      |                         |              |                         |     |               |           |     |
| $0.30 < \Phi$   | 0   |  |                 |                 |                  |                 |                         |                      |                         |              |                         |     |               |           |     |
| 3.2 Line type: (As following drawing)<br> <table border="1" data-bbox="726 1523 1348 1803"> <thead> <tr> <th>Length(mm)</th> <th>Width(mm)</th> <th>Acceptable Q'ty</th> </tr> </thead> <tbody> <tr> <td>---</td> <td><math>W \leq 0.02</math></td> <td>Accept no dense</td> </tr> <tr> <td><math>L \leq 3.0</math></td> <td><math>0.02 &lt; W \leq 0.05</math></td> <td rowspan="2">2</td> </tr> <tr> <td><math>L \leq 2.5</math></td> <td><math>0.03 &lt; W \leq 0.08</math></td> </tr> <tr> <td>---</td> <td><math>0.08 &lt; W</math></td> <td>Rejection</td> </tr> </tbody> </table> <p>* Densely spaced: No more than two lines within 3mm.</p> | Length(mm)  | Width(mm)  | Acceptable Q'ty | ---             | $W \leq 0.02$    | Accept no dense | $L \leq 3.0$            | $0.02 < W \leq 0.05$ | 2                       | $L \leq 2.5$ | $0.03 < W \leq 0.08$    | --- | $0.08 < W$    | Rejection | 2.5 |
| Length(mm)  | Width(mm)   | Acceptable Q'ty  |                 |                 |                  |                 |                         |                      |                         |              |                         |     |               |           |     |
| ---   | $W \leq 0.02$   | Accept no dense  |                 |                 |                  |                 |                         |                      |                         |              |                         |     |               |           |     |
| $L \leq 3.0$  | $0.02 < W \leq 0.05$  | 2  |                 |                 |                  |                 |                         |                      |                         |              |                         |     |               |           |     |
| $L \leq 2.5$  | $0.03 < W \leq 0.08$  |  |                 |                 |                  |                 |                         |                      |                         |              |                         |     |               |           |     |
| ---   | $0.08 < W$  | Rejection  |                 |                 |                  |                 |                         |                      |                         |              |                         |     |               |           |     |

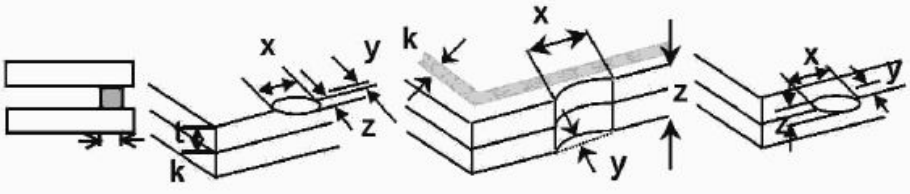
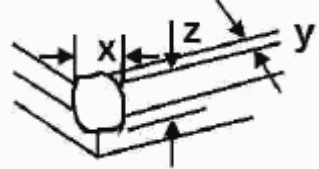
| NO. | Item              | Criterion   |                         | AQL             |                |
|-----|-------------------|---|-------------------------|-----------------|----------------|
| 04  | Polarizer bubbles | If bubbles are visible, judge using black spot specifications, not easy to find, must check in specify direction  | Size $\Phi$ (mm)        | Acceptable Q'ty | 2.5            |
|     |                   |   | $\Phi \leq 0.20$        | Accept no dense |                |
|     |                   |   | $0.20 < \Phi \leq 0.50$ | 3               |                |
|     |                   |   | $0.50 < \Phi \leq 1.00$ | 2               |                |
|     |                   |   | $1.00 < \Phi$           | 0               |                |
|     |                   |   | Total Q'ty              | 3               |                |
| 05  | Scratches         | Follow NO.3 -2 Line Type.   |                         |                 |                |
| 06  | Chipped glass     | <p>Symbols:<br/>                     x: Chip length    y: Chip width    z: Chip thickness<br/>                     k: Seal width    t: Glass thickness    a: LCD side length<br/>                     L: Electrode pad length</p> <p>6.1 General glass chip:<br/>                     6.1.1 Chip on panel surface and crack between panels:</p>  |                         | 2.5             |                |
|     |                   | z: Chip thickness   | y: Chip width           |                 | x: Chip length |
|     |                   | $Z \leq 1/2t$   | Not over viewing area   |                 | $x \leq 1/8a$  |
|     |                   | $1/2t < z \leq 2t$  | Not exceed 1/3k         |                 | $x \leq 1/8a$  |
|     |                   | <p>⊙ Unit: mm<br/>                     ⊙ If there are 2 or more chips, x is the total length of each chip</p>   |                         |                 |                |
|     |                   | <p>6.1.2 Corner crack:</p>   |                         |                 |                |
|     |                   | z: Chip thickness   | y: Chip width           | x: Chip length  |                |
|     |                   | $Z \leq 1/2t$   | Not over viewing area   | $x \leq 1/8a$   |                |
|     |                   | $1/2t < z \leq 2t$  | Not exceed 1/3k         | $x \leq 1/8a$   |                |
|     |                   | <p>⊙ Unit: mm<br/>                     ⊙ If there are 2 or more chips, x is the total length of each chip</p>   |                         |                 |                |

| NO. | Item               | Criterion  | AQL                                      |
|-----|--------------------|--|--|
| 08  | Cracked glass      | The LCD with extensive crack is not acceptable.  | 2.5                                      |
| 09  | Backlight elements | 9.1 Illumination source flickers when lit.<br>9.2 Spots or scratches that appear when lit must be judged. Using LCD spot, lines and contamination standards.<br>9.3 Backlight doesn't light or color is wrong.   | 2.5<br>2.5<br>0.65                       |
| 10  | Bezel              | Bezel must comply with product specifications.   | 2.5                                      |
| 11  | PCB、COB            | 11.1 COB seal may not have pinholes larger than 0.2mm or contamination.<br>11.2 COB seal surface may not have pinholes through to the IC.<br>11.3 The height of the COB should not exceed the height indicated in the assembly diagram.<br>11.4 There may not be more than 2mm of sealant outside the seal area on PCB. And there should be no more than three places.<br>11.5 Parts on PCB must be the same as on the production characteristic chart, There should be no wrong parts, missing parts or excess parts.<br>11.6 The jumper on the PCB should conform to the product characteristic chart. | 2.5<br>2.5<br>2.5<br>2.5<br>0.65<br>0.65 |
| 12  | FPC                | 12.1 FPC terminal damage $\cong$ 1/2 FPC terminal width and can not affect the function, we judge accept.<br>12.2 FPC alignment hole damage $\cong$ 1/2 alignment area and can not affect the function, we judge accept.   | 2.5<br>2.5                               |
| 13  | Soldering          | 13.1 No cold solder joints, missing solder connections, oxidation or icicle.<br>13.2 No short circuits in components on PCB or FPC.  | 2.5<br>0.65                              |

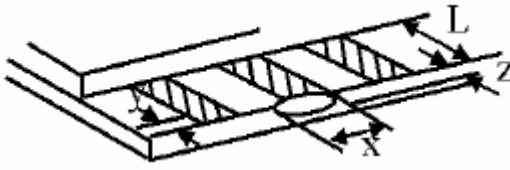
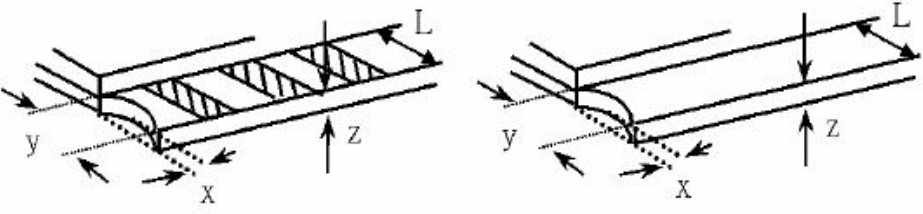
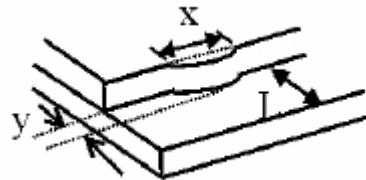
| NO.  | Item           | Criterion   | AQL               |                   |                   |                       |               |                |     |
|--|----------------|---|-------------------|-------------------|-------------------|-----------------------|---------------|----------------|-----|
| 07   | Glass crack    | <p>Symbols:<br/>           x: Chip length    y: Chip width    z: Chip thickness<br/>           k: Seal width    t: Glass thickness    a: LCD side length<br/>           L: Electrode pad length</p> <p>7.2 Protrusion over terminal:<br/>           7.2.1 Chip on electrode pad:</p>  <table border="1" data-bbox="558 761 1236 907"> <tr> <td>y: Chip width</td> <td>x: Chip length</td> <td>z: Chip thickness</td> </tr> <tr> <td><math>y \leq 0.5\text{mm}</math></td> <td><math>x \leq 1/8a</math></td> <td><math>0 &lt; z \leq t</math></td> </tr> </table> | y: Chip width     | x: Chip length    | z: Chip thickness | $y \leq 0.5\text{mm}$ | $x \leq 1/8a$ | $0 < z \leq t$ | 2.5 |
|  |                | y: Chip width   | x: Chip length    | z: Chip thickness |                   |                       |               |                |     |
|  |                | $y \leq 0.5\text{mm}$   | $x \leq 1/8a$     | $0 < z \leq t$    |                   |                       |               |                |     |
| <p>7.2.2<br/>           Non-conductive portion:</p>  <table border="1" data-bbox="558 1276 1236 1422"> <tr> <td>y: Chip width</td> <td>x: Chip length</td> <td>z: Chip thickness</td> </tr> <tr> <td><math>y \leq L</math></td> <td><math>x \leq 1/8a</math></td> <td><math>0 &lt; z \leq t</math></td> </tr> </table>   | y: Chip width  | x: Chip length  | z: Chip thickness | $y \leq L$        | $x \leq 1/8a$     | $0 < z \leq t$        |               |                |     |
| y: Chip width  | x: Chip length | z: Chip thickness   |                   |                   |                   |                       |               |                |     |
| $y \leq L$   | $x \leq 1/8a$  | $0 < z \leq t$  |                   |                   |                   |                       |               |                |     |
| <p>⊙ If there chipped area touches the ITO terminal, over 2/3 of the ITO must remain and be inspected according to electrode terminal specifications.<br/>           ⊙ If the product will be heat sealed by the customer, the alignment mark must not be damaged.</p> <p>7.2.3 Substrate protuberance and internal crack</p>  <table border="1" data-bbox="885 1747 1324 1892"> <tr> <td>y: width</td> <td>x: length</td> </tr> <tr> <td><math>y \leq 1/3L</math></td> <td><math>X \leq a</math></td> </tr> </table> | y: width       | x: length   | $y \leq 1/3L$     | $X \leq a$        |                   |                       |               |                |     |
| y: width   | x: length      |   |                   |                   |                   |                       |               |                |     |
| $y \leq 1/3L$  | $X \leq a$     |   |                   |                   |                   |                       |               |                |     |

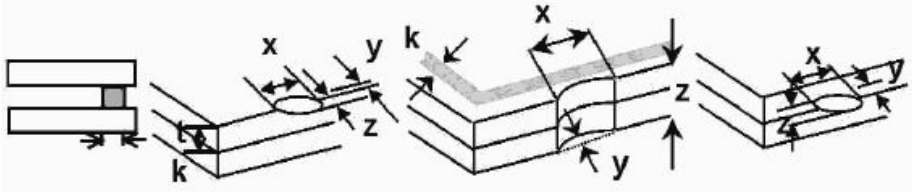
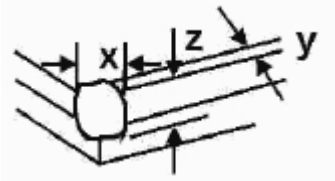

| NO.               | Item                                   | Criterion   | AQL               |               |                |            |  |               |                   |               |                |            |  |               |     |
|-------------------|--|---|-------------------|---------------|----------------|------------|--|---------------|-------------------|---------------|----------------|------------|--|---------------|-----|
| 14                | Touch Panel<br>Chipped<br>glass        | <p>Symbols:<br/>           x: Chip length      y: Chip width      z: Chip thickness<br/>           k: Seal width      t: Touch Panel Total thickness      a: LCD side length<br/>           L: Electrode pad length</p> <p>14.1 General glass chip:<br/>           14.1.1 Chip on panel surface and crack between panels:</p>  <table border="1" data-bbox="451 801 1270 1019"> <tr> <td style="text-align: center;">z: Chip thickness</td> <td style="text-align: center;">y: Chip width</td> <td style="text-align: center;">x: Chip length</td> </tr> <tr> <td style="text-align: center;"><math>Z \leq t</math></td> <td style="text-align: center;"><math>\leq 1/2 k</math> and not over viewing area</td> <td style="text-align: center;"><math>x \leq 1/8a</math></td> </tr> </table> <p>⊙ Unit: mm<br/>           ⊙ If there are 2 or more chips, x is the total length of each chip</p> <p>14.1.2 Corner crack:</p>  <table border="1" data-bbox="451 1400 1270 1617"> <tr> <td style="text-align: center;">z: Chip thickness</td> <td style="text-align: center;">y: Chip width</td> <td style="text-align: center;">x: Chip length</td> </tr> <tr> <td style="text-align: center;"><math>z \leq t</math></td> <td style="text-align: center;"><math>\leq 1/2 k</math> and not over viewing area</td> <td style="text-align: center;"><math>x \leq 1/8a</math></td> </tr> </table> <p>⊙ Unit: mm<br/>           ⊙ If there are 2 or more chips, x is the total length of each chip</p> | z: Chip thickness | y: Chip width | x: Chip length | $Z \leq t$ | $\leq 1/2 k$ and not over viewing area | $x \leq 1/8a$ | z: Chip thickness | y: Chip width | x: Chip length | $z \leq t$ | $\leq 1/2 k$ and not over viewing area | $x \leq 1/8a$ | 2.5 |
| z: Chip thickness | y: Chip width                          | x: Chip length  |                   |               |                |            |  |               |                   |               |                |            |  |               |     |
| $Z \leq t$        | $\leq 1/2 k$ and not over viewing area | $x \leq 1/8a$   |                   |               |                |            |  |               |                   |               |                |            |  |               |     |
| z: Chip thickness | y: Chip width                          | x: Chip length  |                   |               |                |            |  |               |                   |               |                |            |  |               |     |
| $z \leq t$        | $\leq 1/2 k$ and not over viewing area | $x \leq 1/8a$   |                   |               |                |            |  |               |                   |               |                |            |  |               |     |

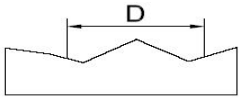
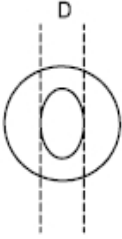
| NO.                | Item  | Criterion  | AQL                          |                 |                 |                 |                    |   |                    |   |           |   |     |
|--------------------|---|--|------------------------------|-----------------|-----------------|-----------------|--------------------|---|--------------------|---|-----------|---|-----|
| 15                 | Touch Panel(Fish eye、dent and bubble on film) | <table border="1" data-bbox="459 353 987 562"> <thead> <tr> <th>SIZE(mm)</th> <th>Acceptable Q'ty</th> </tr> </thead> <tbody> <tr> <td><math>\Phi \leq 0.2</math></td> <td>Accept no dense</td> </tr> <tr> <td><math>0.2 &lt; D \leq 0.4</math></td> <td>5</td> </tr> <tr> <td><math>0.4 &lt; D \leq 0.5</math></td> <td>2</td> </tr> <tr> <td><math>0.5 &lt; D</math></td> <td>0</td> </tr> </tbody> </table>   | SIZE(mm)                     | Acceptable Q'ty | $\Phi \leq 0.2$ | Accept no dense | $0.2 < D \leq 0.4$ | 5 | $0.4 < D \leq 0.5$ | 2 | $0.5 < D$ | 0 | 2.5 |
| SIZE(mm)           | Acceptable Q'ty                               |  |                              |                 |                 |                 |                    |   |                    |   |           |   |     |
| $\Phi \leq 0.2$    | Accept no dense                               |  |                              |                 |                 |                 |                    |   |                    |   |           |   |     |
| $0.2 < D \leq 0.4$ | 5   |  |                              |                 |                 |                 |                    |   |                    |   |           |   |     |
| $0.4 < D \leq 0.5$ | 2   |  |                              |                 |                 |                 |                    |   |                    |   |           |   |     |
| $0.5 < D$          | 0   |  |                              |                 |                 |                 |                    |   |                    |   |           |   |     |
| 16                 | Touch Panel Newton ring                       | Newton ring dimension $\leq 1/2$ touch panel area and not affect font and line distortion ( $\leq 2.5\%$ ), it is acceptable.  | 2.5                          |                 |                 |                 |                    |   |                    |   |           |   |     |
| 17                 | Touch Panel Linearity                         | Less than 2.5% is acceptable.  | 2.5                          |                 |                 |                 |                    |   |                    |   |           |   |     |
| 18                 | LCD Ripple                                    | Touch the touch panel, cannot see the LCD ripple.<br>Pen: R 1.0mm silicon rubber.<br>Operation Force: 80g  | 2.5                          |                 |                 |                 |                    |   |                    |   |           |   |     |
| 19                 | General appearance                            | 19.1 Pin type must match type in specification sheet.<br>19.2 LCD pin loose or missing pins.<br>19.3 Product packaging must the same as specified on packaging specification sheet.<br>19.4 Product dimension and structure must conform to product specification sheet.   | 0.65<br>0.65<br>0.65<br>0.65 |                 |                 |                 |                    |   |                    |   |           |   |     |

## 11. Handling Precaution

### 11.1 Handling of LCM

- Avoid external shock.
- Don't apply excessive force on the surface.
- Liquid in LCD is hazardous substance, do not lick or swallow. When the liquid is attaching to your hand, skin, cloth, etc., wash it thoroughly and immediately.
- Don't operate it above the absolute maximum rating.
- Don't disassemble the LCM.
- The operators should wear protections whenever he/she comes into contact with the module. Never touch any of the conductive parts such as the LSI pads, the copper leads on the PCB and the interface terminals with any parts of the human body.
- The modules should be kept in antistatic bags or other containers resistant to static for storage.
- The module is coated with a film to protect the display surface, be careful when peeling off this protective film since static electricity may be generated.

### 11.2 Storage

- Store it in an ambient temperature of  $25\pm 10^{\circ}\text{C}$ , and in a relative humidity of  $50\pm 10\%\text{RH}$ . Don't expose to sunlight or fluorescent light.
- Store it in a clean environment, free from dust, active gas, and solvent.
- Store it in anti-static electricity container.
- Store it without any physical load.

### 11.3 Soldering

- Use only soldering irons with proper grounding and no leakage.
- Iron: no higher than  $280\pm 10^{\circ}\text{C}$  and less than 3 sec during hand soldering.
- Rewiring: no more than 2 times.

## 12. Packing Method

----TBD