

TECENSTAR

Add:	5/F, Building B, Xingnan Industrial Zone, Lianping Administrative District, Dalingshan Town, Dongguan, China		
Tel:	+86-769-8286 8210	Fax:	+86-769 8286 8212

SPECIFICATION

COG-T500MTWH-03

- Preliminary Specification
- Final Specification



**TECENSTAR PHOTOELECTRIC
TECHNOLOGY CO., LTD.**

CUSTOMER:

Made By:

Checked By:

Approved By:

Quality:

Date:

Note:

Approved By:

Date:

Note:

Contents

1. General Specification.....	4
2. Mechanical Drawing.....	5
3. Block Diagram.....	6
4. Interface Pin Function.....	7
5. Absolute Maximum Ratings.....	8
6. Electrical Characteristics.....	9
7. Optical Characteristics.....	10
8. Timing Characteristics.....	13
9. Standard Specification for Reliability.....	15
10. General Precautions.....	16
11. Packing Method.....	16

1. General Specification

Item	Contents	Unit
LCD TYPE	TFT/TRANSMISSIVE	
MODULE SIZE (W*H*T)	120.7*75.80*3.10	MM
ACTIVE SIZE (W*H)	108.00*64.80	MM
PIXEL PITCH (W*H)	0.135*0.135	MM
NUMBER OF DOTS	800*480	
DIVER IC	HX8664B+HX8264D	
INTERFACE TYPE	24-BIT RGB	
TOP POLARIZER TYPE	ANTI-GLARE	
RECOMMEND VIEWING DIRECTION	12	O'CLOCK
GRAY SCALE INVERSION DIRECTION	6	O'CLOCK
COLORS	16.7M	
BACKLIGHT TYPE	12-DIES WHITE LED	
TOUCH PANEL TYPE	WITHOUT	

2. Mechanical Drawing

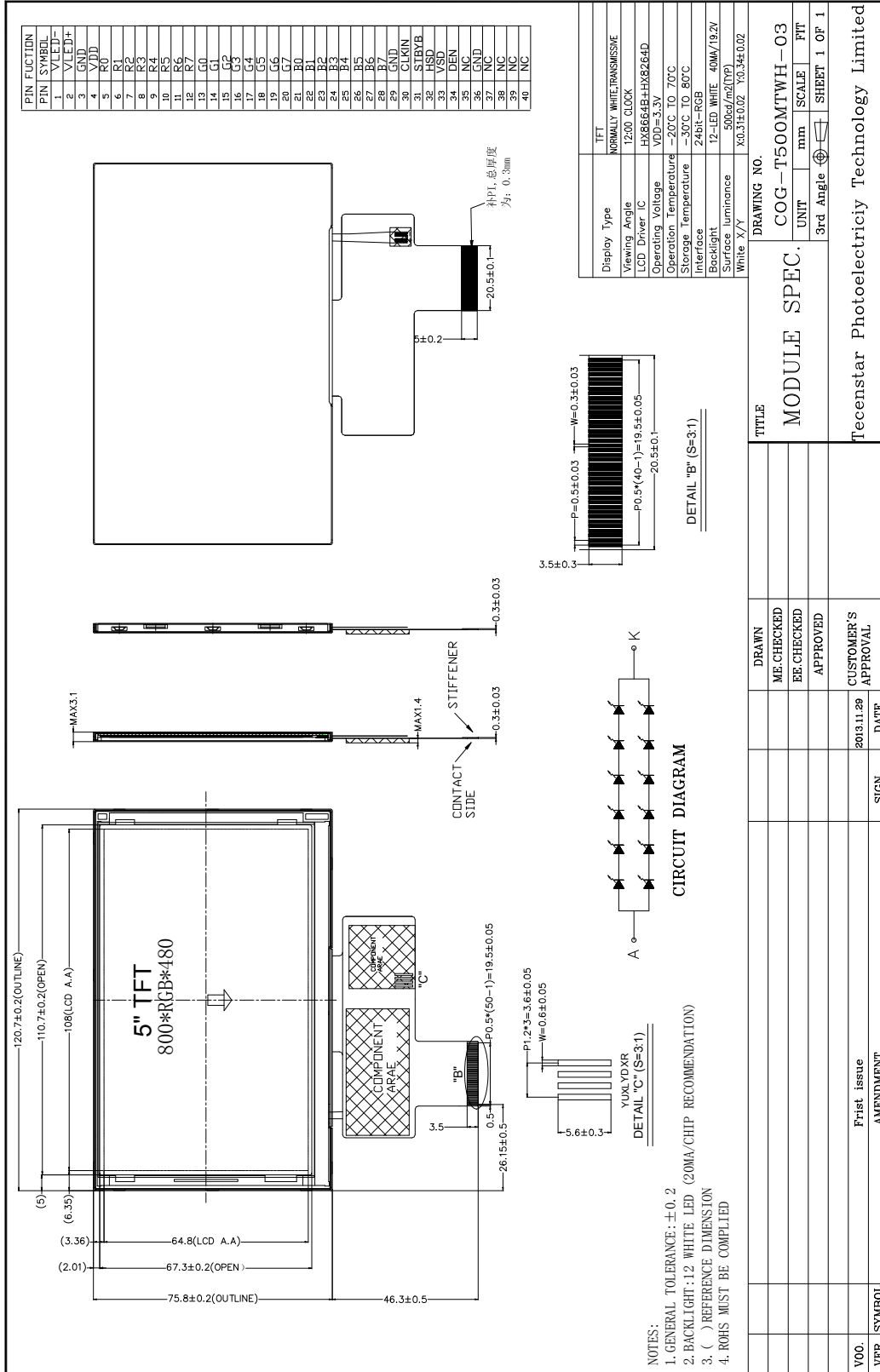

3. Block Diagram

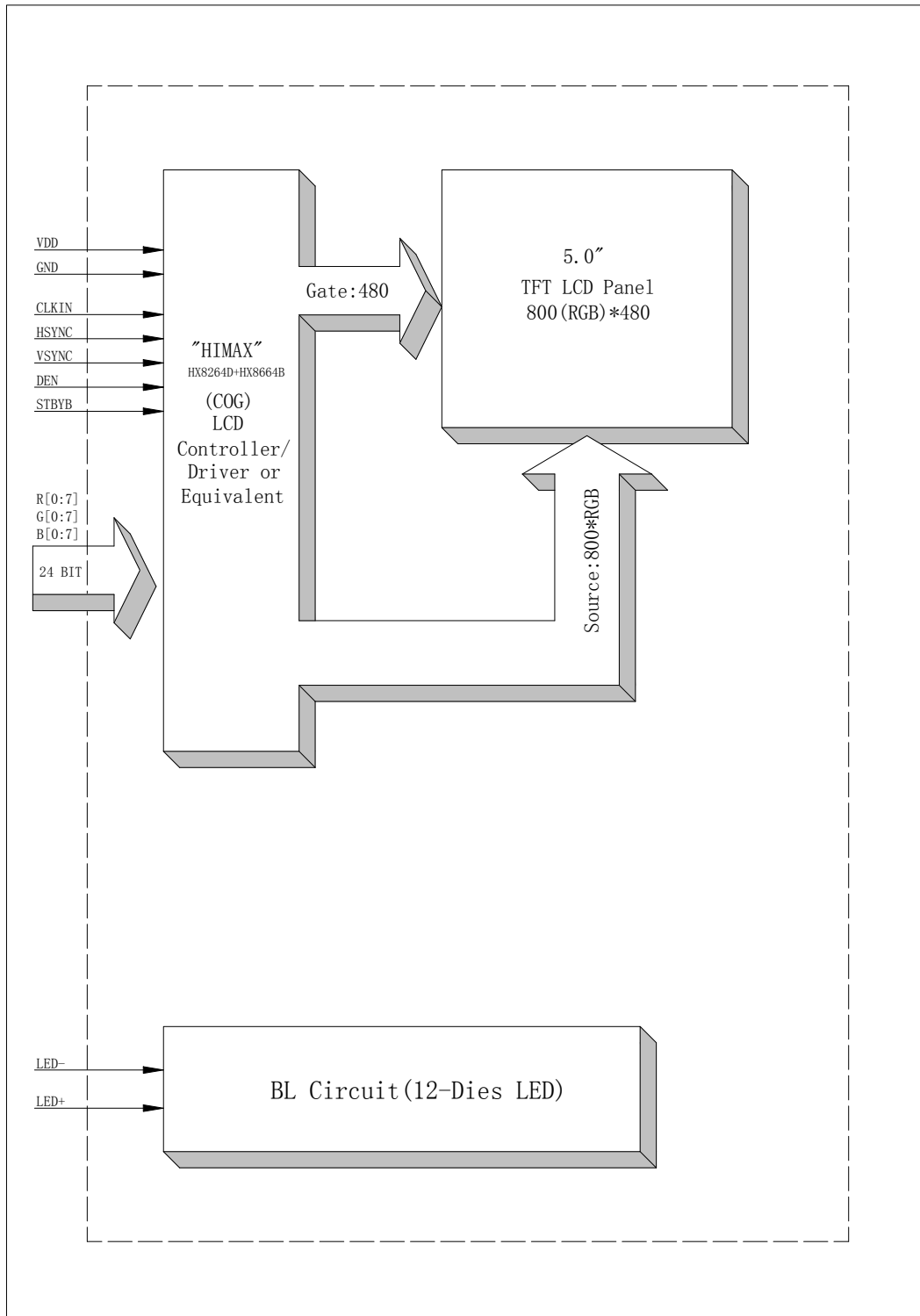

4. Interface Pin Function

Pin No.	Symbol	Description
1	LED-	Cathode of LED backlight
2	LED+	Anode of LED backlight
3	GND	Power ground
4	VDD	Power supply
5~12	R0~R7	8-bit digital Red data input,
13~20	G0~G7	8-bit digital Green data input,
21~28	B0~B7	8-bit digital Blue data input,
29	GND	Power ground
30	CLKIN	Clock signal; latching data at the falling edge
31	STBYB	Display control / standby mode selection. STBYB = "Low" : Standby; STBYB = "High" : Normal display(Default)
32	HSD	Horizontal sync signal; negative polarity
33	VSD	Vertical sync signal; negative polarity
34	DEN	Data input enable. Active High to enable the data input.
35	NC	No connection.
36	GND	Power ground
37	NC	No connection.
38	NC	No connection.
39	NC	No connection.
40	NC	No connection.

5. Absolute Maximum Ratings

Parameter	Symbol	Min	Max	Unit
Supply voltage for analog	VDD	-0.3	4.5	V
Supply voltage for logic	VDD	-0.5	4.5	V
Supply current (One LED)	I _{LED}		60	mA
Operating temperature	T _{OP}	-20	+70	°C
Storage temperature	T _{ST}	-30	+80	°C

Note: The absolute maximum rating values of this product are not allowed to be exceeded at any times. Should a module be used with any of the absolute maximum ratings exceeded, the characteristics of the module may not be recovered, or in an extreme case, the module may be permanently destroyed.

6. Electrical Characteristics

6.1 Input Power

Item	Symbol	Min	Typ.	Max	Unit	Applicable terminal
Supply Voltage for Analog	VDD	3.0	3.3	3.6	V	
Supply Voltage for Logic	VDD	3.0	3.3	3.6	V	
Input Voltage	V _{IL}	GND	-	0.2VDD	V	
	V _{IH}	0.8 VDD	-	VDD		
Input leakage Current	I _{LKG}	-		-	μA	

6.2 Backlight Driving Conditions

Item	Symbol	Value			Unit	Remark
		Min.	Typ.	Max.		
Voltage for LED Backlight	V _F	-	19.2	-	V	I _L =40mA
Current for LED Backlight	I _L		40		mA	
Power Consumption	P		0.768		W	
LED Life Time		30,000			Hr	Note

Note: Brightness to be decreased to 50% of the initial value at ambient temperature TA=25°C

7. Optical Characteristics

ITEM	SYMBOL	CONDITIONS	SPECIFICATIONS			UNIT	NOTE
			MIN	TYP.	MAX		
Luminance	L	$I_L = 40\text{mA}$		500		Cd/m^2	
Contrast Ratio	CR	$\theta = 0^\circ$		500			
Response Time	T_{ON}	25°C		20		ms	
	T_{OFF}						
CIE Color Coordinate	Red	X_R	Viewing normal angle				
		Y_R					
	Green	X_G					
		Y_G					
	Blue	X_B					
		Y_B					
	White	X_W			0.310		
		Y_W			0.340		
Viewing Angle	Hor.	θ_{X+}	$CR \geq 10$	60	70	Degree	
		θ_{X-}		60	70		
	Ver.	θ_{Y+}		40	50		
		θ_{Y-}		60	70		
Uniformity	Un			75	80	%	

Note 1: Definition of Viewing Angle θ_x and θ_y :

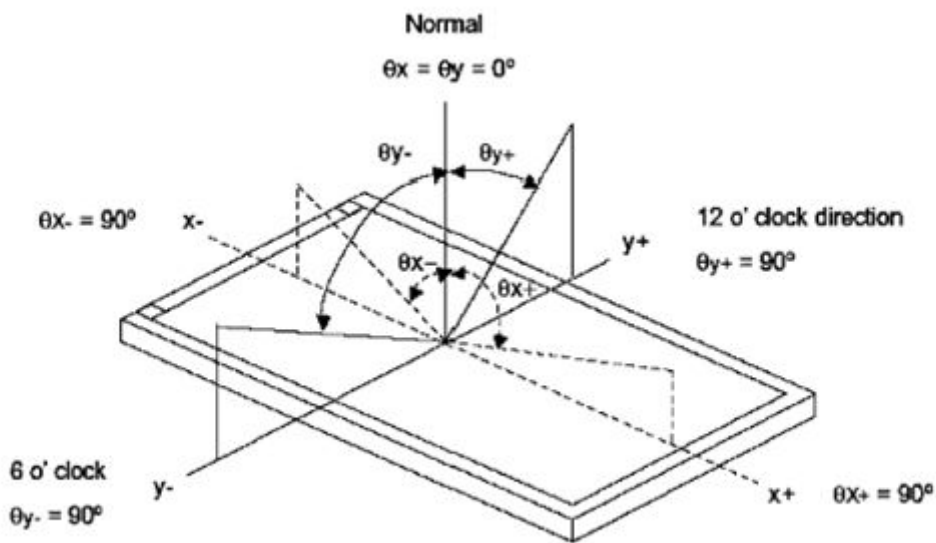

Note 2: Definition of contrast ratio CR:

$$CR = \frac{\text{Luminance of white state}}{\text{Luminance of black state}}$$

Note 3: Definition of Response Time (T_r, T_f)

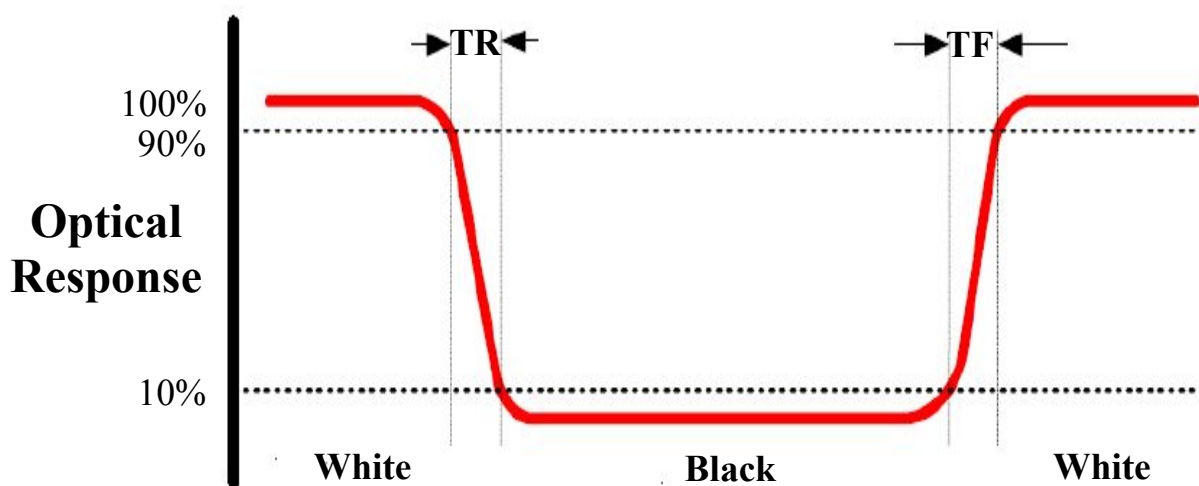

Note 4: Definition of Luminance

①The Brightness Test Equipment Setup

Field=2° (As measuring “black” image, field=2° is the best testing condition)

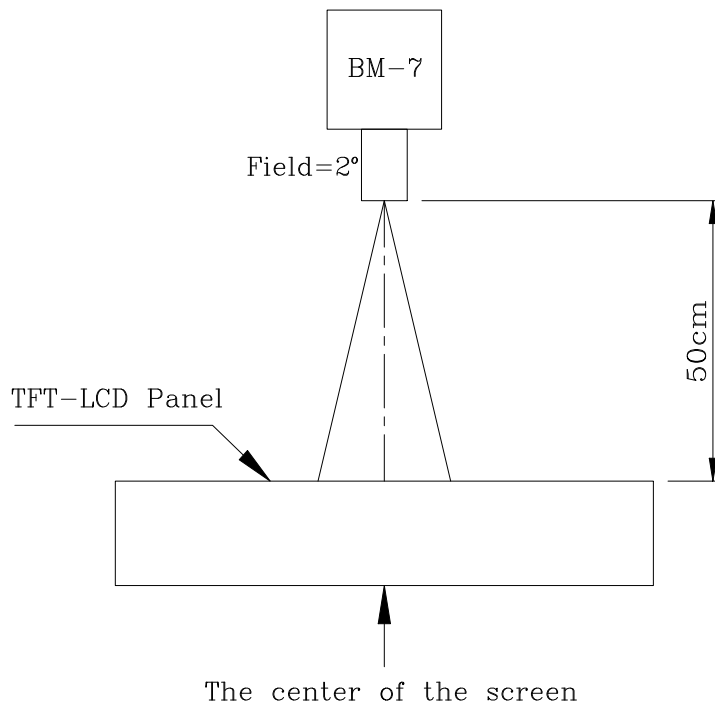

②The Brightness Test Point Setup

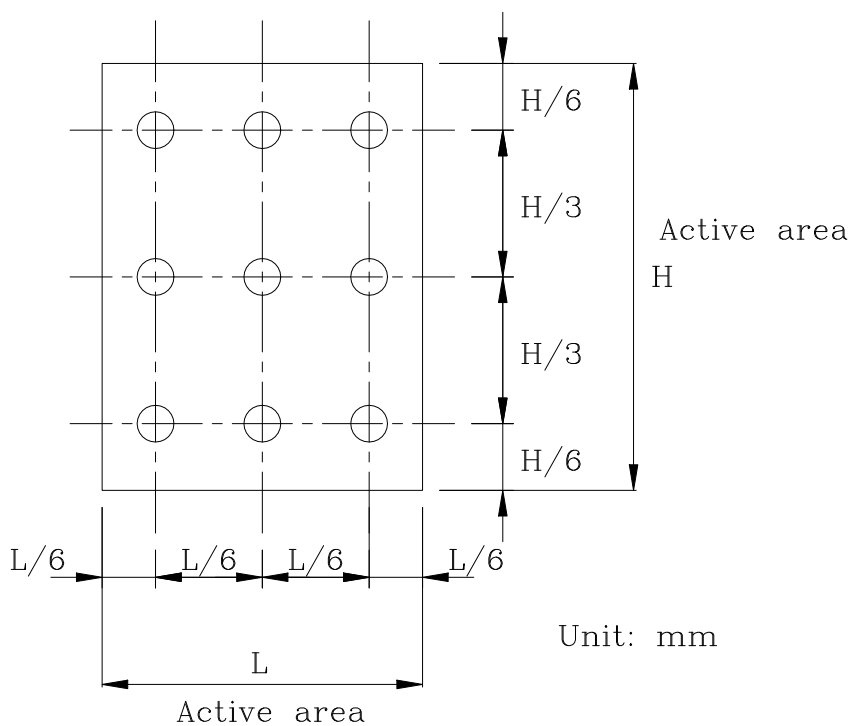

8. Timing Characteristics

8.1 RGB Mode Timing Diagram

- Horizontal timing

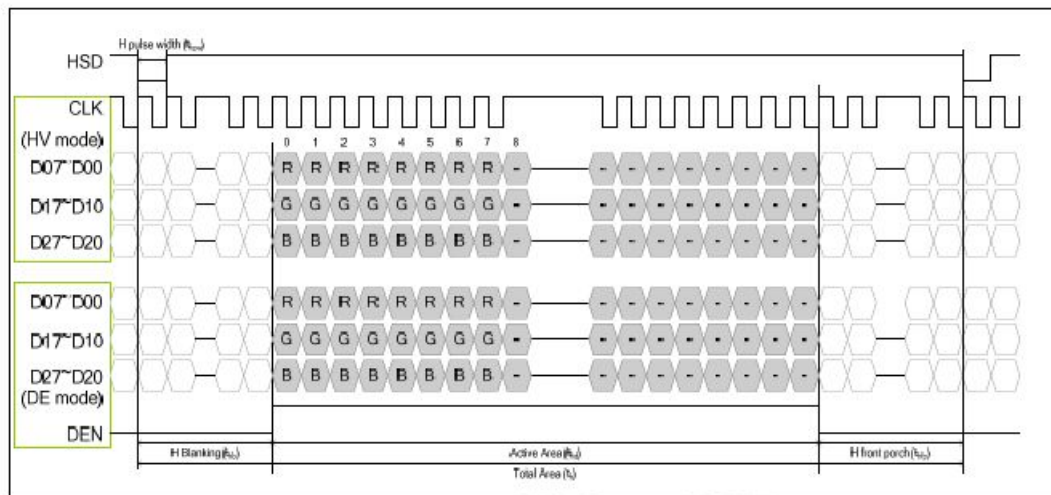

Figure 11.1: Horizontal Input Timing Diagram

- Vertical timing

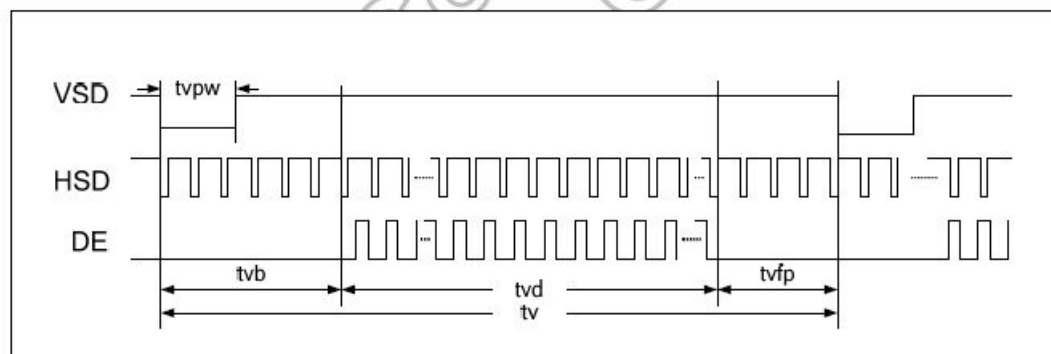

Figure 11.2: Vertical Input Timing Diagram

8.2 RGB Timing Table

- Horizontal timing

Parameter	Symbol	Spec.			Unit
		Min.	Typ.	Max.	
Horizontal Display Area	thd	800			DCLK
DCLK frequency	fclk	-	30	50	MHz
One Horizontal Line	th	862	1056	1200	DCLK
HS pulse width	thpw	1	-	40	DCLK
HS Back Porch (Blanking)	thb	46			DCLK
HS Front Porch	thfp	16	210	354	DCLK
DE mode Blanking	th-thd	85	256	400	DCLK

- Vertical timing

Parameter	Symbol	Spec.			Unit
		Min.	Typ.	Max.	
Vertical Display Area	tvd	480			T _H
VS period time	tv	513	525	650	T _H
VS pulse width	tvpw	3	-	20	T _H
VS Back Porch (Blanking)	tvb	23			T _H
VS Front Porch	tvfp	7	22	147	T _H
DE mode Blanking	tv-tvd	30	45	170	T _H

Parameter	Symbol	Min.	Typ.	Max.	Unit	Conditions
CLKIN Frequency	Fclk	-	40	50	MHz	VDD=3.0V~3.6V
CLKIN Cycle Time	Tclk	20	25	-	ns	-
CLKIN Pulse Duty	Tcwh	40	50	60	%	Tclk
Time from HSD to Source Output	Thso	64			CLKIN	-
Time from HSD to LD	Thld	64			CLKIN	-
Time from HSD to STV	Thstv	2			CLKIN	-
Time from HSD to CKV	Thckv	20			CLKIN	-
Time from HSD to OEV	Thoev	4			CLKIN	-
LD Pulse Width	Twld	10			CLKIN	-
CKV Pulse Width	Twckv	66			CLKIN	-
OEV Pulse Width	Twoev	74			CLKIN	-

9. Standard Specification for Reliability

9.1 Standard Specification for Reliability of LCD Module

Item	Test Conditions	Remark
High temperature storage	Ta=80°C 240hrs	NOTE1 , NOTE4
Low temperature storage	Ta=-30°C 240hrs	NOTE1 , NOTE4
High temperature operation	Ta=70°C 240hrs	NOTE2 , NOTE4
Low temperature operation	Ta=-20°C 240hrs	NOTE2 , NOTE4
Operate at high temperature and humidity	+60°C, 90%RH 240hrs	NOTE4
Thermal Shock	-30°C/30min~+80°C/30min for a total 100 cycles, start with cold temperature and end with high temperature.	NOTE4
Vibration Test	Frequency range:10~55HZ Stroke:1.5mm Swap:10HZ~55HZ~10HZ 2 hours of each direction of X.Y. Z (6 hours for total)	
Mechanical shock	100G 6ms, ±X, ±Y, ±Z 3 times for each direction	
Package vibration test	Random vibration :0.15G*G/HZ from 5-200 HZ,-6dB/Octave from 200-500HZ of each direction of X.Y. Z (6 hours for total)	
Low temperature storage	Height:60cm 1 corner ,3 edges ,6 surfaces	
Low temperature storage	±2KV ,Human Body Mode, 100pF/1500Ω	

Note 1: Ta is the ambient temperature of samples.

Note 2: Ts is the temperature of panel's surface.

Note 3: In the standard condition, there shall be no practical problem that may affect the display function. After the reliability test, the product only guarantees operation, but don't guarantee all of the cosmetic specification.

Note 4: Before cosmetic and function test, the product must have enough recovery time, at least 2 hours at room temperature.

10. General Precautions

10.1. Safety

- Liquid crystal is poisonous. Do not put it in your mouth. If liquid crystal touches your skin or clothes, wash it off immediately by using soap and water.

10.2. Handling

- The LCD panel is plate glass. Do not subject the panel to mechanical shock or to excessive force on its surface.
- The polarizer attached to the display is easily damaged. Please handle it carefully to avoid scratch or other damages.
- To avoid contamination on the display surface, do not touch the module surface with bare hands.
- Keep a space so that the LCD panels do not touch other components.
- Put cover board such as acrylic board on the surface of LCD panel to protect panel from damages.
- Transparent electrodes may be disconnected if you use the LCD panel under environmental conditions where the condensation of dew occurs.
- Do not leave module in direct sunlight to avoid malfunction of the ICs.

10.3. Static Electricity

- Be sure to ground module before turning on power or operating module.
- Do not apply voltage which exceeds the absolute maximum rating value.

10.4. Storage

- Store the module in a dark room where must keep at $25\pm 10^{\circ}\text{C}$ and 65%RH or less.
- Do not store the module in surroundings containing organic solvent or corrosive gas.
- Store the module in an anti-electrostatic container or bag.

10.5. Cleaning

- Do not wipe the polarizer with dry cloth. It might cause scratch.
- Only use a soft sloth with IPA to wipe the polarizer, other chemicals might permanent damage to the polarizer.

11. Packing Method

----TBD