

TECENSTAR

Add:	5/F, Building B, Xingnan Industrial Zone, Lianping Administrative District, Dalingshan Town, Dongguan, China		
Tel:	+86-769-8286 8210	Fax:	+86-769 8286 8212

SPECIFICATION

COG-T700MIWH-05

- Preliminary Specification
- Final Specification



**TECENSTAR PHOTOELECTRIC
TECHNOLOGY CO., LTD.**

CUSTOMER:

Made By:

Checked By:

Approved By:

Quality:

Date:

Note:

Approved By:

Date:

Note:

Records of Revision

DATE	REF.PAGE PARAGRAPH DRAWING No.	REVISED No.	SUMMARY	REMARK
2015-11-25		V01	First Issue	

Contents

1. General Specification.....	4
2. Mechanical Drawing.....	5
3. Block Diagram.....	6
4. Interface Pin Function.....	7
5. Absolute Maximum Ratings.....	8
6. Electrical Characteristics.....	9
7. Optical Characteristics.....	100
8. Timing Characteristics.....	13
9. Standard Specification for Reliability.....	16
10. General Precautions.....	17
11. Packing Method.....	17

1. General Specification

Item	Contents	Unit
LCD TYPE	TFT/TRANSMISSIVE	
MODULE SIZE (W*H*T)	165.00*104.54*5.20	MM
ACTIVE SIZE (W*H)	152.40*91.44	MM
PIXEL PITCH (W*H)	0.150*0.150	MM
NUMBER OF DOTS	800*480	
DIVER IC	HX8262+HX8678	
INTERFACE TYPE	18-BIT RGB	
TOP POLARIZER TYPE	ANTI-GLARE	
RECOMMEND VIEWING DIRECTION	12	O'CLOCK
GRAY SCALE INVERSION DIRECTION	6	O'CLOCK
COLORS	262K	
BACKLIGHT TYPE	24-LED WHITE	
TOUCH PANEL TYPE	WITHOUT	

2. Mechanical Drawing

Pin Symbol

1	LED
2	LED
3	VCC
4	VCC
5	VCC
6	VCC
7	VCC
8	VCC
9	LED
10	LED
11	LED
12	LED
13	LED
14	LED
15	LED
16	LED
17	LED
18	LED
19	LED
20	LED
21	LED
22	LED
23	LED
24	LED
25	LED
26	LED
27	LED
28	LED
29	LED
30	LED
31	LED
32	LED
33	LED
34	LED
35	LED
36	LED
37	LED
38	LED
39	LED
40	LED

Display Type TFT
Viewing Angle TRANSMISSIVE POSITIVE
Upper Controller Type Z80 CLOCK
Logic Voltage VCC=3.3V
Operation Temperature -20°C TO 70°C
Storage Temperature -30°C TO 80°C
Backlight 24-LED WHITE 160mA/9.6V
Surface luminance >300cd/m²(TYP.)
White X/Y ---

Backlight Circuit
 (3*8=24LED, 20mA/LED)

NOTES:
 1. GENERAL TOLERANCE: ±0.2
 2. REFERENCE DIMENSION
 3. RECOMMENDED CUSHION ADHERENT AREA: TP V.A+1.6mm
 4. REFERENCED DIMENSION: ()
 5. REQUIREMENTS ON ENVIRONMENTAL PROTECTION: ROHS

MODULE SPEC.
 DRAWING NO. COG-T700MIWH-05
 UNIT mm SCALE PTT
 3rd Angle SHEET 1 OF 1

TITLE
 BE CHECKED
 APPROVED
 CUSTOMER'S APPROVAL
 2004.11.27
 DATE
 SIGN

Tecenstar Photoelectricity Technology Limited

3. Block Diagram

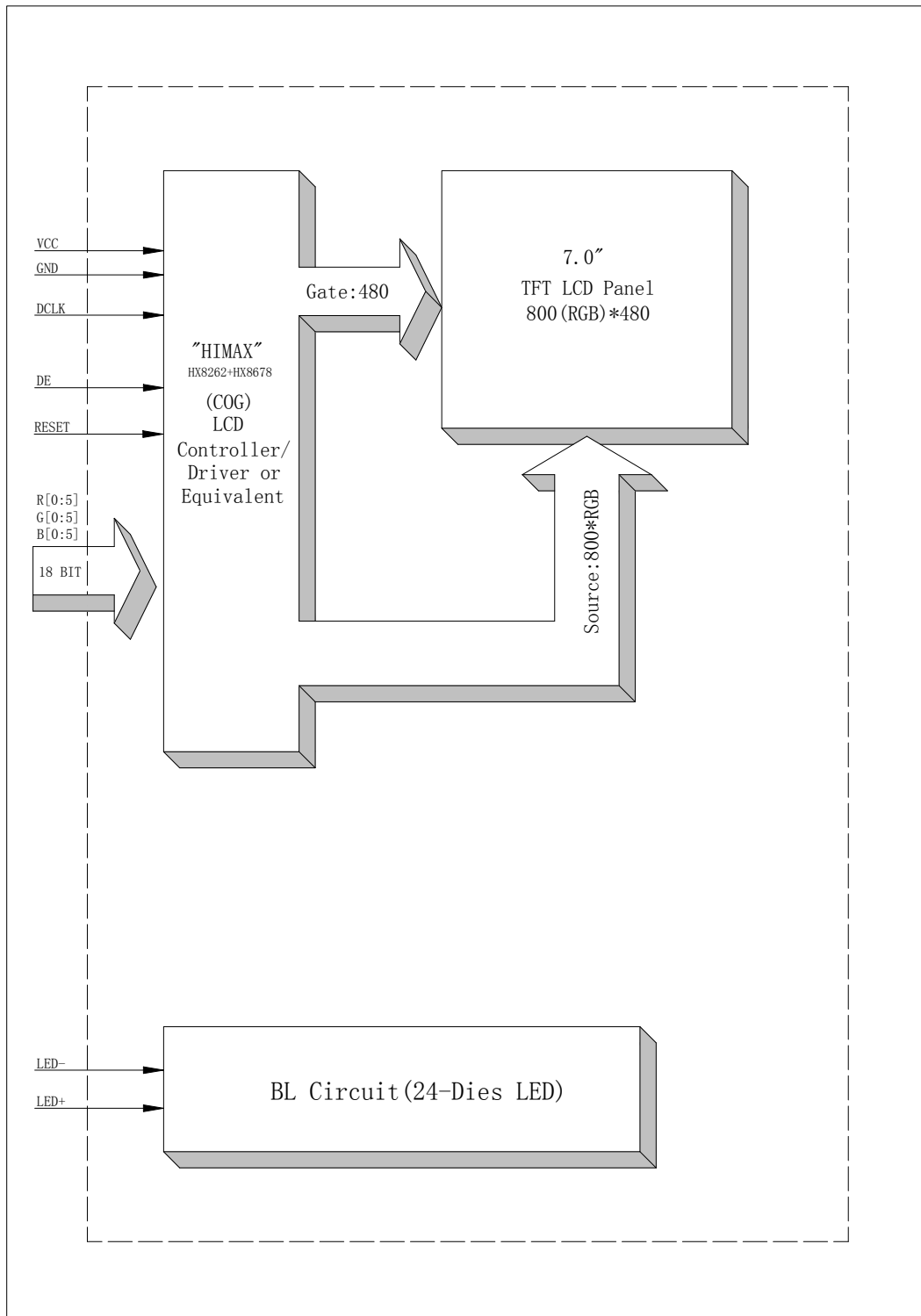

4. Interface Pin Function

Pin No.	Symbol	Description
1	GND	Power ground
2	GND	Power ground
3	NC	No connect
4	VCC	Power supply
5	VCC	Power supply
6	VCC	Power supply
7	VCC	Power supply
8	NC	No connect
9	DE	Data Input Enable
10	GND	Power ground
11	GND	Power ground
12	GND	Power ground
13	B5	Blue data
14	B4	Blue data
15	B3	Blue data
16	GND	Power ground
17	B2	Blue data
18	B1	Blue data
19	B0	Blue data
20	GND	Power ground
21	G5	Green data
22	G4	Green data
23	G3	Green data
24	GND	Power ground
25	G2	Green data
26	G1	Green data
27	G0	Green data
28	GND	Power ground
29	R5	Red data
30	R4	Red data
31	R3	Red data
32	GND	Power ground
33	R2	Red data
34	R1	Red data
35	R0	Red data
36	GND	Power ground
37	GND	Power ground
38	DCLK	Pixel clock signal
39	GND	Power ground
40	GND	Power ground

5. Absolute Maximum Ratings

Parameter	Symbol	Min	Max	Unit
Supply voltage for logic	VCC	-0.3	5	V
Supply voltage for analog	AVDD	6.5	13.5	V
Power supply	VGH	-0.3	40	V
Power supply	VGL	-20	0.3	V
Power supply	VGH-VGL	-	40	V
Supply current (One LED)	I _{LED}		30	mA
Operating temperature	T _{OP}	-20	+70	°C
Storage temperature	T _{ST}	-30	+80	°C

Note: The absolute maximum rating values of this product are not allowed to be exceeded at any times. Should a module be used with any of the absolute maximum ratings exceeded, the characteristics of the module may not be recovered, or in an extreme case, the module may be permanently destroyed.

6. Electrical Characteristics

6.1 Input Power

Item	Symbol	Min	Typ.	Max	Unit	Applicable terminal
Supply Voltage for Analog	VCC	3.0	3.3	3.6	V	
Supply Voltage for Logic	AVDD	10.2	10.4	10.6	V	
Power supply	VGH	16	18	19		
Power supply	VGL	-7	-6	-5		
Power supply	VCOM	4.1	4.6	5.1		
Input Voltage	V _{IL}	0.7DVDD	-	DVDD	V	
	V _{IH}	0.7 DVDD	-	DVDD		
Input leakage Current	I _{LKG}	-		-	μA	

6.2 Backlight Driving Conditions

Item	Symbol	Value			Unit	Remark
		Min.	Typ.	Max.		
Voltage for LED Backlight	V _F	-	9.6	10.8	V	I _L =160mA
Current for LED Backlight	I _L		160		mA	
Power Consumption	P		1.536		W	
LED Life Time		30,000			Hr	Note

Note: Brightness to be decreased to 50% of the initial value at ambient temperature TA=25°C

7. Optical Characteristics

ITEM	SYMBOL	CONDITIONS	SPECIFICATIONS			UNIT	NOTE
			MIN	TYP.	MAX		
Luminance	L	$I_L = 140\text{mA}$	-	430	-	Cd/m^2	
Contrast Ratio	CR	$\theta = 0^\circ$	150	250			
Response Time	T_{ON}	25°C		10	20	ms	
	T_{OFF}			15	30		
CIE Color Coordinate	Red	X_R	Viewing normal angle				
		Y_R					
	Green	X_G					
		Y_G					
	Blue	X_B					
		Y_B					
	White	X_W			0.300		
		Y_W			0.340		
Viewing Angle	Hor.	θ_{X+}	$\text{CR} \geq 10$		45	Degree	
		θ_{X-}			45		
	Ver.	θ_{Y+}			15		
		θ_{Y-}			35		
Uniformity	Un		70	75		%	

Note 1: Definition of Viewing Angle θ_x and θ_y :

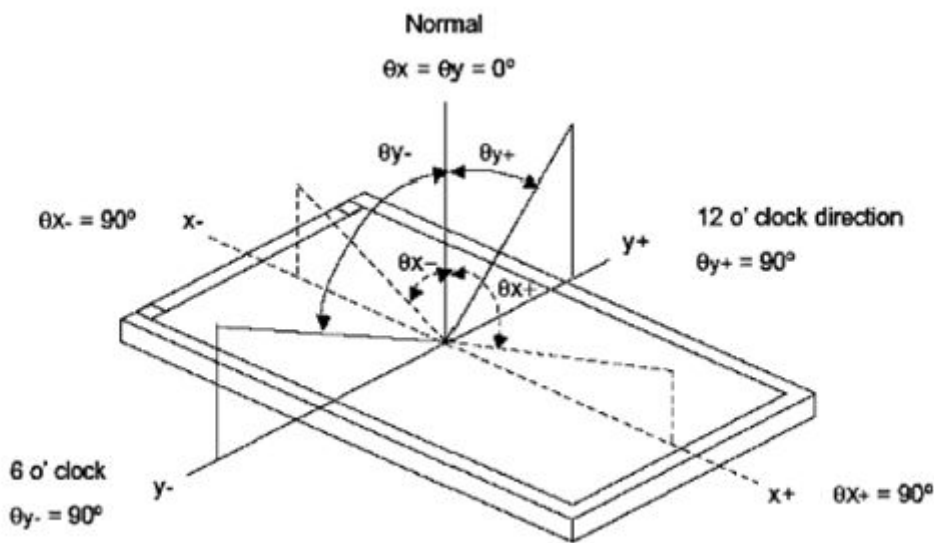

Note 2: Definition of contrast ratio CR:

$$CR = \frac{\text{Luminance of white state}}{\text{Luminance of black state}}$$

Note 3: Definition of Response Time (T_r, T_f)

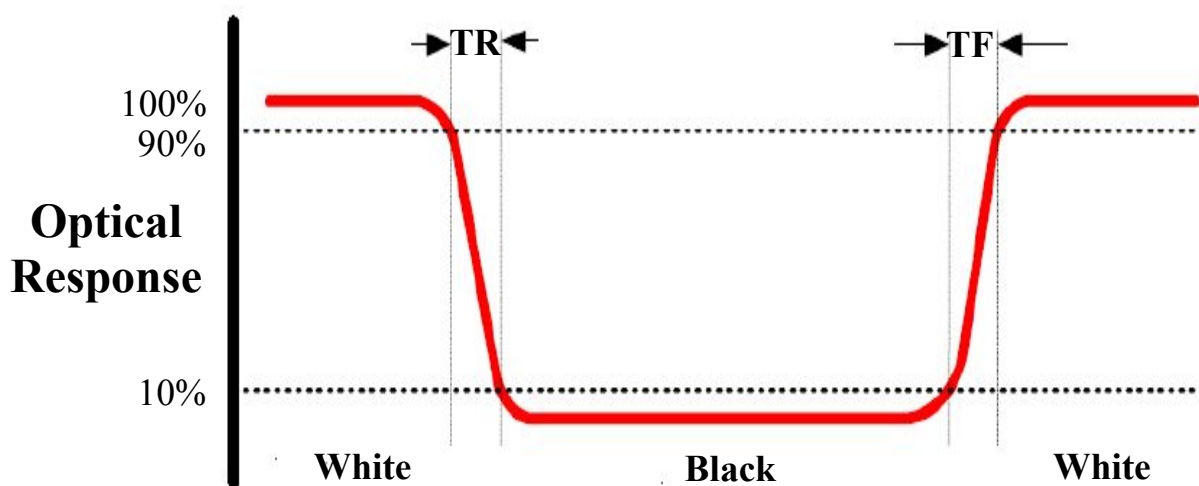

Note 4: Definition of Luminance

①The Brightness Test Equipment Setup

Field=2° (As measuring “black” image, field=2° is the best testing condition)

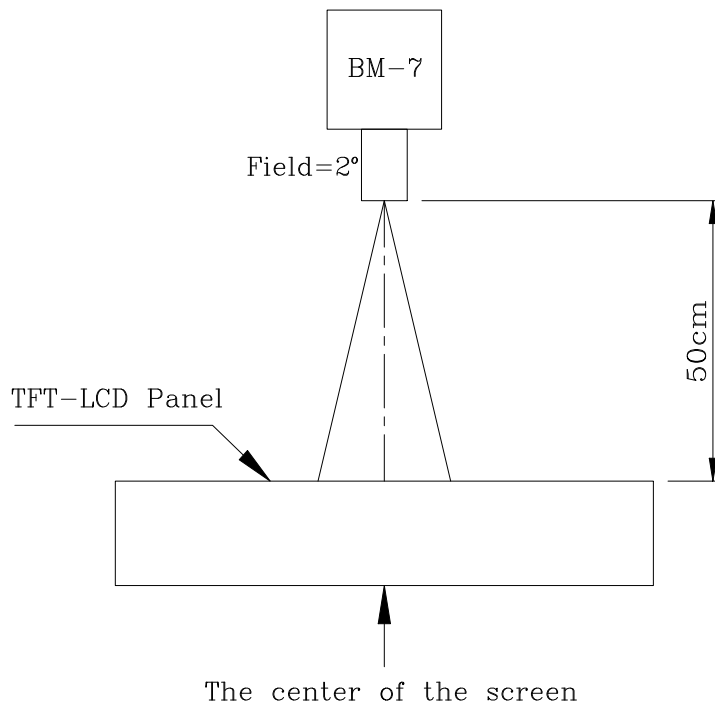

②The Brightness Test Point Setup

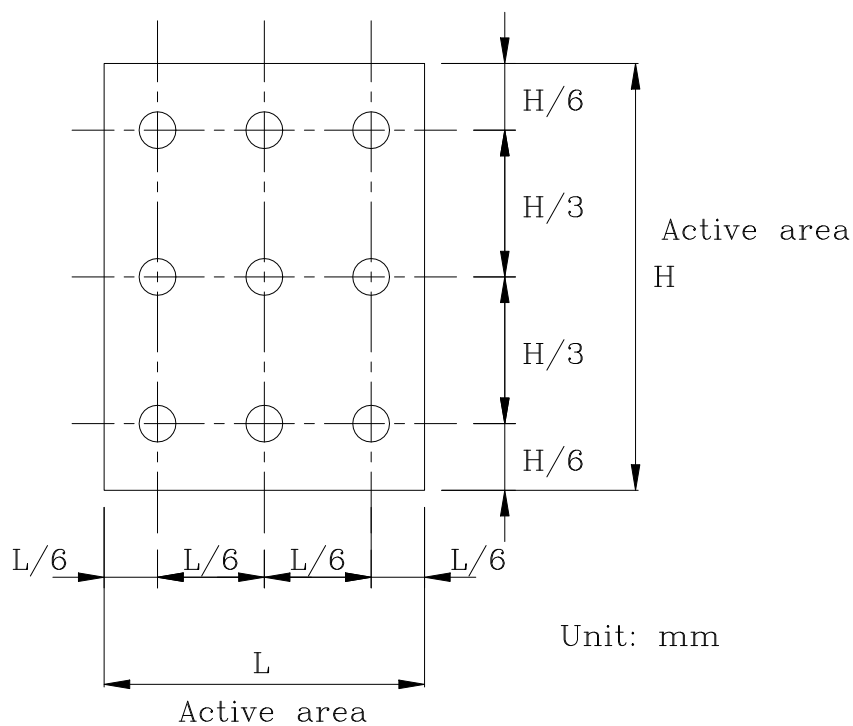

8. Timing Characteristics

8.1 Power Sequence

Power on

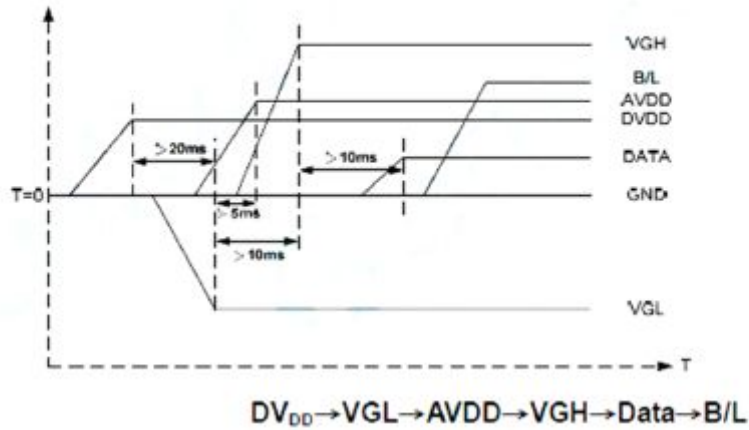

Power off

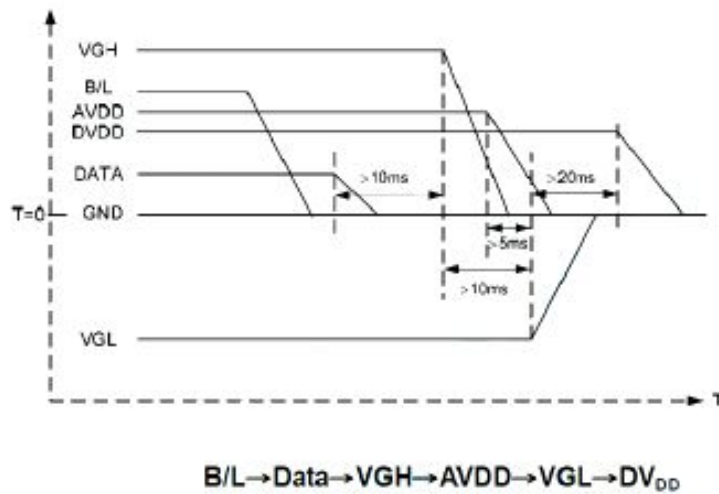

8.2 AC electrical characteristics

Parameter	Symbol	Spec.			Unit
		Min.	Typ.	Max.	
HS setup time	T_{hst}	6	-	-	ns
HS hold time	T_{hhd}	6	-	-	ns
VS setup time	T_{vst}	6	-	-	ns
VS hold time	T_{vhd}	6	-	-	ns
Data setup time	T_{dsu}	6	-	-	ns
Data hold time	T_{dhd}	6	-	-	ns
DE setup time	T_{esu}	6	-	-	ns
Source output settling time	T_{ST}	-	-	15	μ s
Source output loading R	R_{SL}	-	2	-	K ohm
Source output loading C	C_{SL}	-	60	-	pF

8.3 RGB Timing Table

- Sync mode

Parameter	Symbol	Spec.			Unit
		Min.	Typ.	Max.	
CLK frequency	F_{CPH}	29.93	33.26	36.59	MHz
CLK period	T_{CPH}	-	30.06	-	ns
CLK pulse duty	T_{CWH}	40	50	60	%
HS period	T_H	930	1056	1057	T_{CPH}
HS pulse width	T_{WH}	1	128	-	T_{CPH}
HS-first horizontal data time	T_{HS}	STHD[7:0]+88			T_{CPH}
HS Active Time	T_{HA}	-	800	-	T_{CPH}
VS period	T_V	490	525	526	T_H
VS pulse width	T_{WV}	1	2	-	T_H
VS-DE time	T_{VS}	STVD[6:0]+8			T_H
VS Active Time	T_{VA}	-	480	-	T_H

Note: (1) $T_{HS}+T_{HA}<T_H$

- DE mode

Parameter	Symbol	Spec.			Unit
		Min.	Typ.	Max.	
CLK frequency	F_{CPH}	29.4	33.26	42.48	MHz
CLK period	T_{CPH}	-	30.06	-	ns
CLK pulse duty	T_{CWH}	40	50	60	%
DE period	$T_{DEH}+T_{DEL}$	1000	1056	1200	T_{CPH}
DE pulse width	T_{DEH}	-	800	-	T_{CPH}
DE frame blanking	T_{DEB}	10	45	110	$T_{DEH}+T_{DEL}$
DE frame width	T_{DE}	-	480	-	$T_{DEH}+T_{DEL}$

Note: (1) DE frame blanking(T_{DEB}) must be the integer of DE period($T_{DEH}+T_{DEL}$)

Parameter	Symbol	Min.	Spec.	Max.	Unit
			Typ.		
OEV pulse width	T_{OEV}	-	150	-	T_{CPH}
CKV pulse width	T_{CKV}	-	133	-	T_{CPH}
DE(internal)-STV time	T_1	-	4	-	T_{CPH}
DE(internal)-CKV time	T_2	-	40	-	T_{CPH}
DE(internal)-OEV time	T_3	-	23	-	T_{CPH}
DE(internal)-POL time	T_4	-	157	-	T_{CPH}
STV pulse width	-	-	1	-	T_H

8.4 Data input format

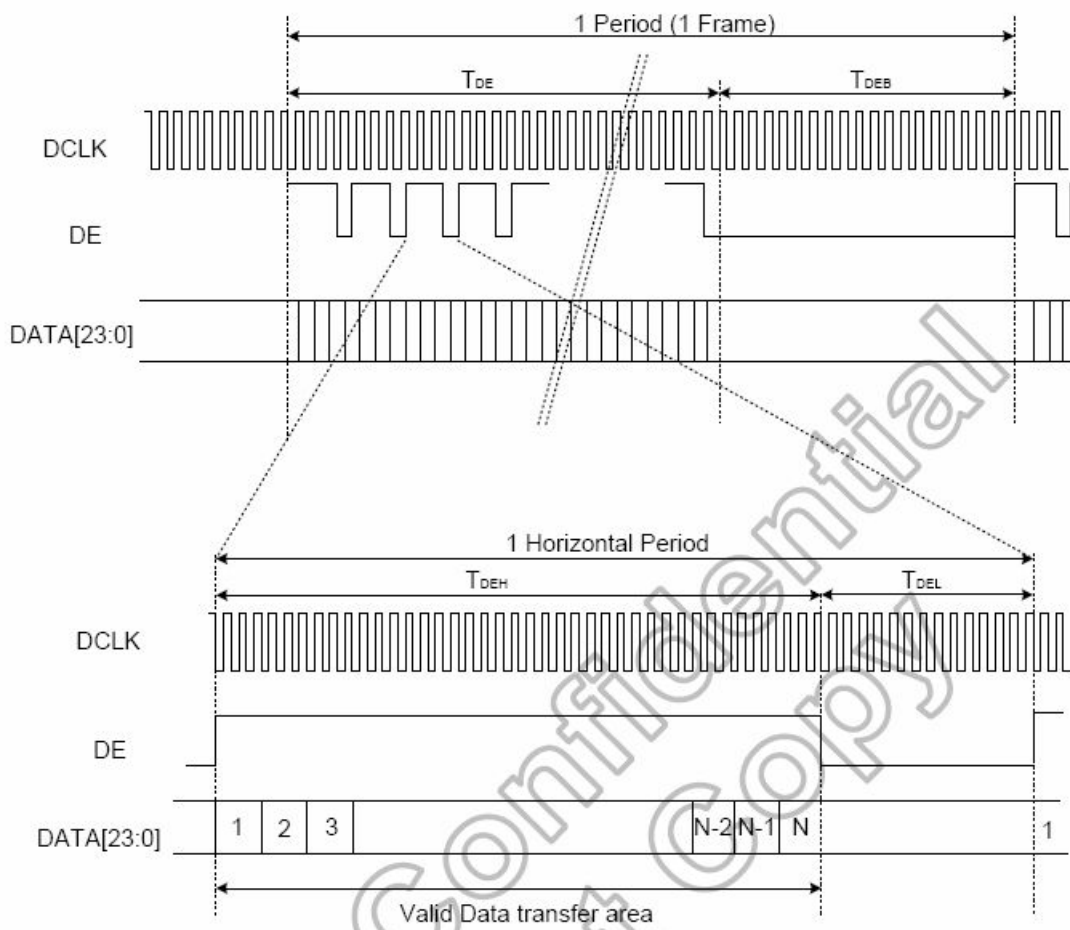

9. Standard Specification for Reliability

9.1 Standard Specification for Reliability of LCD Module

Item	Test Conditions	Remark
High temperature storage	Ta=80°C 240hrs	NOTE1 , NOTE4
Low temperature storage	Ta=-30°C 240hrs	NOTE1 , NOTE4
High temperature operation	Ta=70°C 240hrs	NOTE2 , NOTE4
Low temperature operation	Ta=-20°C 240hrs	NOTE2 , NOTE4
Operate at high temperature and humidity	+60°C, 90%RH 240hrs	NOTE4
Thermal Shock	-30°C/30min~+80°C/30min for a total 100 cycles, start with cold temperature and end with high temperature.	NOTE4
Vibration Test	Frequency range:10~55HZ Stroke:1.5mm Swap:10HZ~55HZ~10HZ 2 hours of each direction of X.Y. Z (6 hours for total)	
Mechanical shock	100G 6ms, ±X, ±Y, ±Z 3 times for each direction	
Package vibration test	Random vibration :0.15G*G/HZ from 5-200 HZ,-6dB/Octave from 200-500HZ of each direction of X.Y. Z (6 hours for total)	
Low temperature storage	Height:60cm 1 corner ,3 edges ,6 surfaces	
Low temperature storage	±2KV ,Human Body Mode, 100pF/1500Ω	

Note 1: Ta is the ambient temperature of samples.

Note 2: Ts is the temperature of panel's surface.

Note 3: In the standard condition, there shall be no practical problem that may affect the display function. After the reliability test, the product only guarantees operation, but don't guarantee all of the cosmetic specification.

Note 4: Before cosmetic and function test, the product must have enough recovery time, at least 2 hours at room temperature.

10. General Precautions

10.1. Safety

- Liquid crystal is poisonous. Do not put it in your mouth. If liquid crystal touches your skin or clothes, wash it off immediately by using soap and water.

10.2. Handling

- The LCD panel is plate glass. Do not subject the panel to mechanical shock or to excessive force on its surface.
- The polarizer attached to the display is easily damaged. Please handle it carefully to avoid scratch or other damages.
- To avoid contamination on the display surface, do not touch the module surface with bare hands.
- Keep a space so that the LCD panels do not touch other components.
- Put cover board such as acrylic board on the surface of LCD panel to protect panel from damages.
- Transparent electrodes may be disconnected if you use the LCD panel under environmental conditions where the condensation of dew occurs.
- Do not leave module in direct sunlight to avoid malfunction of the ICs.

10.3. Static Electricity

- Be sure to ground module before turning on power or operating module.
- Do not apply voltage which exceeds the absolute maximum rating value.

10.4. Storage

- Store the module in a dark room where must keep at $25\pm 10^{\circ}\text{C}$ and 65%RH or less.
- Do not store the module in surroundings containing organic solvent or corrosive gas.
- Store the module in an anti-electrostatic container or bag.

10.5. Cleaning

- Do not wipe the polarizer with dry cloth. It might cause scratch.
- Only use a soft sloth with IPA to wipe the polarizer, other chemicals might permanent damage to the polarizer.

11. Packing Method

----TBD